

I give permission for public access to my thesis and for copying to be done at the discretion of the archives' librarian and/or the College library.

Signature

Date

A Comparative Study of Forelimb Muscle Recruitment During Landing in Three
Anuran Species: *Rana catesbeiana*, *Rana pipiens* and *Bufo marinus*

by

Erica Levin

A Paper Presented to the
Faculty of Mount Holyoke College in
Partial Fulfillment of the Requirements for
the Degree of Bachelors of Arts with
Honor

Department of Biological Sciences

South Hadley, MA 01075

May 2012

This paper was prepared
under the direction of
Professor Gary Gillis
for eight credits.

ACKNOWLEDGEMENTS

I would like to thank Professor Gary Gillis for all his support throughout this process and Dr. Laura Macesic for her help with experiments, making figures, and moral support. Funding from National Science Foundation grant IOS-1051603 made this project possible. I thank my fellow lab mates, Rebecca Hicks, Hilary Katz, and Eleni Karagiannis for their help with running experiments. Finally, I thank my family and friends who have supported me throughout this process.

TABLE OF CONTENTS

	Page
List of Figures	v
List of Tables	viii
Abstract	ix
Introduction	1
Materials and Methods	19
Results	31
Discussion	52
Literature Cited	60

LIST OF FIGURES

	Page
Figure 1. Diagram of Skeletal Muscle Organization	4
Figure 2. Diagram of a Sarcomere of a Muscle	4
Figure 3. Diagram of a Motor Unit	6
Figure 4. Diagram of a Neuromuscular Junction	6
Figure 5. Diagram of a Muscle Fiber	8
Figure 6. Example EMG Signal with Jump parts labeled	9
Figure 7. Diagram of the Parts of a Jump	11
Figure 8. Picture of a Bullfrog	14
Figure 9. Picture of a Grass Frog	14
Figure 10. Picture of a Cane Toad	16
Figure 11. Anuran Phylogenetic Tree	17
Figure 12. Diagram of Frog Pectoral Girdle	21
Figure 13. Diagram of Bones of Frog Head and Trunk	21
Figure 14. Picture Showing Location of Coracoradialis	23
Figure 15. Picture Showing Location of Anconeus	23

Figure 16. Picture of a 15-pin Female Connector	25
Figure 17. Example of a Binning Graph	29
Figure 18. Diagram of the Timing of the Phases of the Jump in Grass Frogs and Bullfrogs	34
Figure 19. Graph of the Timing of Take-off vs. Distance in Grass Frogs and Bullfrogs	35
Figure 20. Graph of the Timing of Aerial Phase vs. Distance in Grass Frogs and Bullfrogs	36
Figure 21. Graph of the timing of Landing vs. Distance in Grass Frogs and Bullfrogs	37
Figure 22. Example EMG Signal and Average Binning Graph of the Coracoradialis in Grass Frogs	40
Figure 23. Example EMG Signal and Average Binning Graph of the Coracoradialis in Bullfrogs	41
Figure 24. Example EMG Signal of the Anconeus in Grass Frogs from Onset of Movement.....	42
Figure 25. Example EMG Signal and Average Binning Graph of the Anconeus in Grass Frogs	43
Figure 26. Example EMG Signal of the Anconeus in Bullfrogs from Onset of Movement.....	44
Figure 27. Example EMG Signal and Average Binning Graph of the Anconeus in Bullfrogs	45

Figure 28. Graphs of the Onset Latency of the Coracoradialis Against Distance in the Grass Frog and Bullfrog	47
Figure 29. Graphs of the Pre-Landing Intensity of the Coracoradialis Against Distance in the Grass Frog and Bullfrog	48
Figure 30. Graphs of the Onset Latency of the Anconeus Against Distance in the Grass Frog and Bullfrog	50
Figure 31. Graphs of the Pre-Landing Intensity of the Anconeus Against Distance in the Grass Frog and Bullfrog	51
Figure 32. Example Coracoradialis EMG Signal from a 25 cm Jumps in a Grass Frog, Bullfrog and Cane Toad	55
Figure 33. Example Anconeus EMG Signal from a 25 cm Jump in a Grass Frog, Bullfrog and Cane Toad	56

LIST OF TABLES

	Page
Table 1. A Table of the Number Range and Average Distance of the Jumps of All of the Grass Frogs	29
Table 2. A Table of the Number Range and Average Distance of the Jumps of All of the Bullfrogs	30

ABSTRACT

Muscles are what allow animals to walk, jump, run and swim. While they are important in generating the force and power required for propulsive movements, they also are integral to slowing down, serving to absorb energy during decelerations and stopping. In previous studies, *Bufo marinus*, the cane toad, has been shown to alter the timing and intensity of pre-landing forelimb muscle activity depending on the hop distance. For example, longer hops lead to more intense pre-landing muscle recruitment in muscles acting at the elbow. In this study I tested whether similar modulation in forelimb muscle recruitment was present in two distantly related anuran species, *Rana catesbeiana*, the bullfrog, and *Rana pipiens*, the leopard frog, which inhabit more aquatic habitats than *Bufo marinus*.

I found that similar to *Bufo marinus*, some leopard frogs and bullfrogs showed the ability to tune the timing and intensity of pre-landing muscle recruitment to the distance of the jump. These data indicate that the ability to modulate forelimb muscle recruitment patterns prior to landing is not just present in terrestrial toads but is more widespread and is even found in frogs that often jump into water.

INTRODUCTION

Anurans are a group of amphibians that consists of all the frog and toad species. As amphibians, most anurans spend time both in water and on land. They are ectothermic animals that generally live in and around wetlands, including lakes, rivers and ponds (Noble, 1931). As adults, all anurans are quadrupeds, although their hind limbs are relatively longer than their forelimbs and their feet are often webbed (Ecker, 1889). Many move about using saltatory locomotion, jumping and hopping, though some can walk (Wells, 2007) and many can swim.

To jump or hop an anuran will take off using its legs to thrust itself into the air. It will then land with its forelimbs hitting the ground first and having to resist most of the force from landing (Gillis et al., 2010; Nauwelaerts and Aerts, 2005; Peters et al., 1996). Many studies have focused on the role of hindlimb muscles in propelling animals into the air (Gillis and Biewener, 2000; Roberts and Marsh, 2003; Kargo and Rome, 2002). Recently, attention has begun to be paid to the role of forelimb muscles involved in stabilizing the body during landing (Gillis et al., 2010 & Akella and Gillis, 2011)

Jumping humans and other mammals are known to tune the timing and recruitment of limb muscles important in resisting impact based on the height of the jump (Mckinley et. al, 1983; Santello and McDonagh, 1998). For example, when cats jump down from a platform, the onset of forelimb muscle recruitment consistently occurs at a fixed interval before landing regardless of the height of

the jump (Mckinley et. al, 1983). In other words, muscles get turned on later during jumps from higher surfaces to account for the longer “air time” required to reach the ground. In humans jumping or dropping down from different heights, pre-landing muscle activity at the ankle also begins at a nearly fixed interval before impact regardless of height (Santello and McDonagh, 1998). In addition, the intensity of pre-landing activity in the ankle muscles increases with increased height, keeping the ankle from rotating incorrectly and becoming injured (Santello and McDonagh, 1998). This ability of various mammals to alter or tune the timing and recruitment intensity of limb muscles associated with resisting landing impact raises the question of whether more animals, including those outside mammals, can do it.

Recent work has shown that *Bufo marinus*, the cane toad, is able to alter forelimb muscle recruitment patterns to prepare to land from jumps of varying distance (Akella and Gillis, 2011). The cane toad is a terrestrial toad that is not found commonly in water. What remains unknown is whether this ability is limited to these more terrestrial anurans or whether it is more widespread. In this study I test whether such tuning occurs in *Rana catesbeiana* (bullfrog), and *Rana pipiens* (grass frog), two species that, while closely related to each other, are more distant from toads (Hoegg et al, 2004) and have different niches (USGS, 2011), often jumping into water rather than onto land.

Skeletal Muscle Structure and Recruitment

The musculoskeletal system is made up of the bones, muscles, tendons, and joints of the body. Skeletal muscle makes up the largest percentage of the body by weight. It allows animals to walk, stand, jump, or make almost any other kind of movement. Skeletal muscle is made of muscle fibers, the physiological unit or cell of a muscle. These fibers are arranged in bunches of fascicles that are surrounded by perimysium, a dense connective tissue (Figure 1). The entire muscle is covered by another layer of connective tissue known as the epimysium which allows blood vessels and nerves to enter into the muscle (Alberts et al., 2009) and provide the energy and nutrients needed for normal function.

The muscle fibers themselves are made up of smaller filaments known as myofibrils (Figure 1). The myofibrils contain the contractile machinery of the muscle. Each myofibril is made up of many sarcomeres (Figure 2), the smallest unit that can still perform all the functions of a muscle (Alberts et al., 2009). These sarcomeres are made up of actin and myosin, which allow the muscle to contract and relax. In the sarcomere the large filaments (myosin) form the center and are surrounded by the smaller actin filaments which point inward from the z-disk where they are attached (Figure 2). When activated, the myosin walks along the actin filaments shortening the muscle fiber (Alberts et al., 2009). When this activation occurs in many fibers at once, the entire muscle shortens creating the muscle contraction and generating mechanical force.

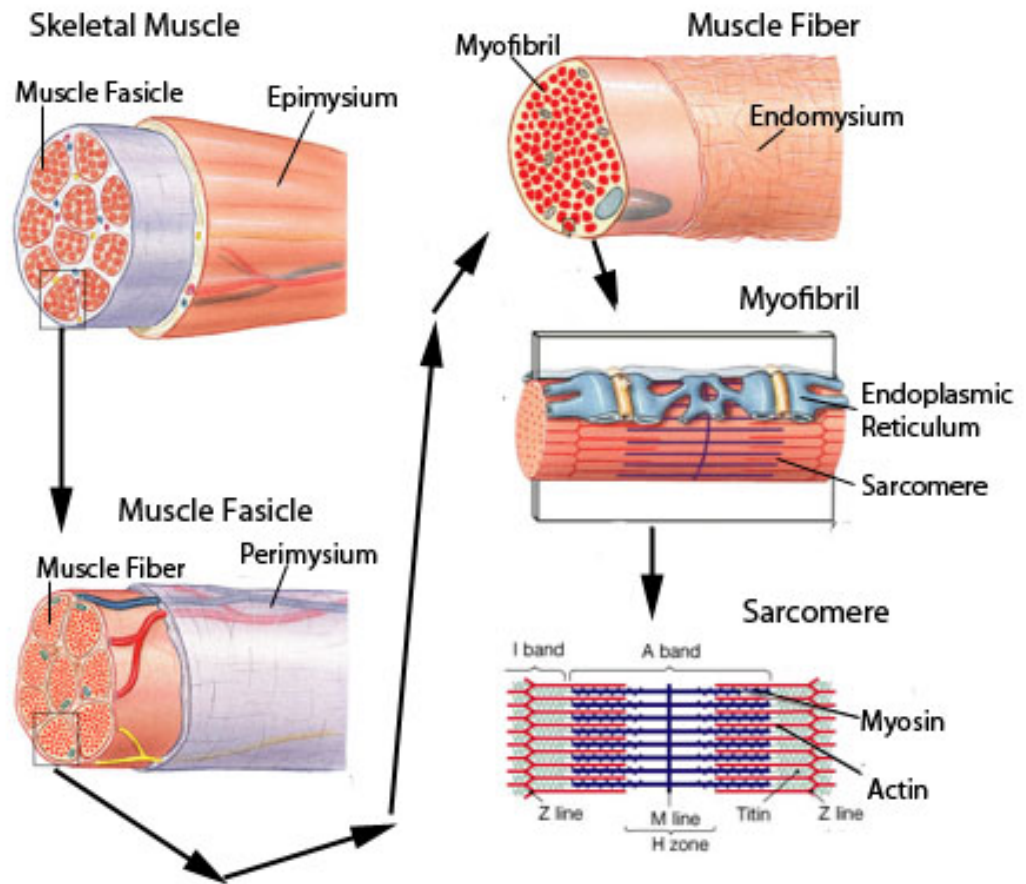

Figure 1. A diagram of how skeletal muscle is organized. Image from Campbell et al., 2004.

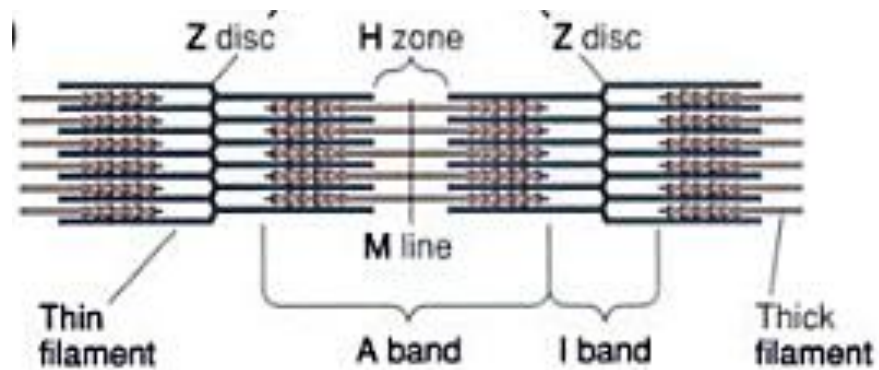

Figure 2. A single sarcomere showing both the actin and myosin filaments and their relationship to one another. Image from Plowman and Smith, 2008.

Skeletal muscle contraction is controlled by the nervous system, and must be initiated by nerve impulses (Alberts et al., 2009). These impulses are provided by motor neurons that synapse with the muscle at the neuromuscular junction. One motor neuron generally synapses with many muscle fibers. The motor neuron and all the muscle fibers it synapses with make up a motor unit (Figure 3). Most muscles have many motor units, which allow for gradations in the force produced during different muscle contractions (Alberts et al., 2009). When less force is needed, fewer motor units are used than when a large amount of force is needed.

The motor unit (Figure 3) is generally triggered by electrical signals (action potentials) from the central nervous system. When such a signal reaches the neuromuscular junction (Figure 4) the influx of calcium into the axon terminal triggers the release of acetylcholine which binds to receptors present on the muscle fiber (Alberts et al., 2009). The binding of acetylcholine triggers an action potential in the muscle fiber (muscle action potential), which is relayed to the sarcoplasmic reticulum (Figure 5). The sarcoplasmic reticulum is a specialized portion of endoplasmic reticulum in muscle cells that surrounds the myofibril and contains a very high concentration of calcium, which is released in response to a muscle action potential (Alberts et al., 2009). The released calcium interacts with the protein complexes associated with the actin filaments in the cell, allowing actin and myosin to interact (Figure 2), initiating the muscle contraction.

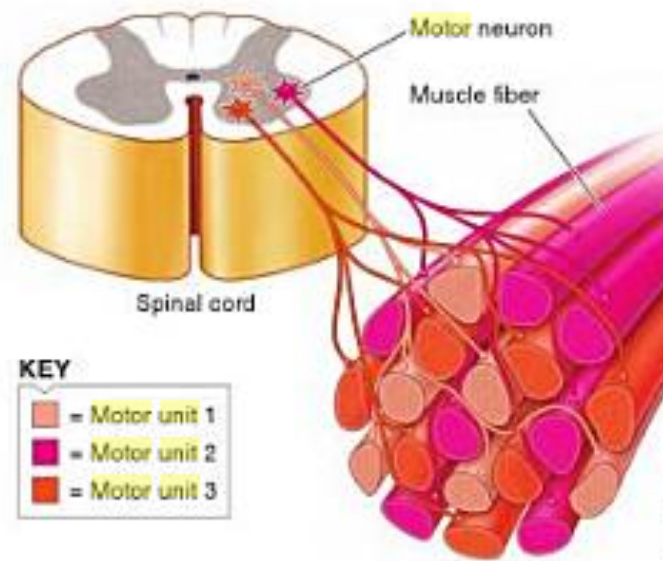

Figure 3. Three motor units showing the muscle fibers and the motor neurons synapsing with them. Image from Sherwood, 2010.

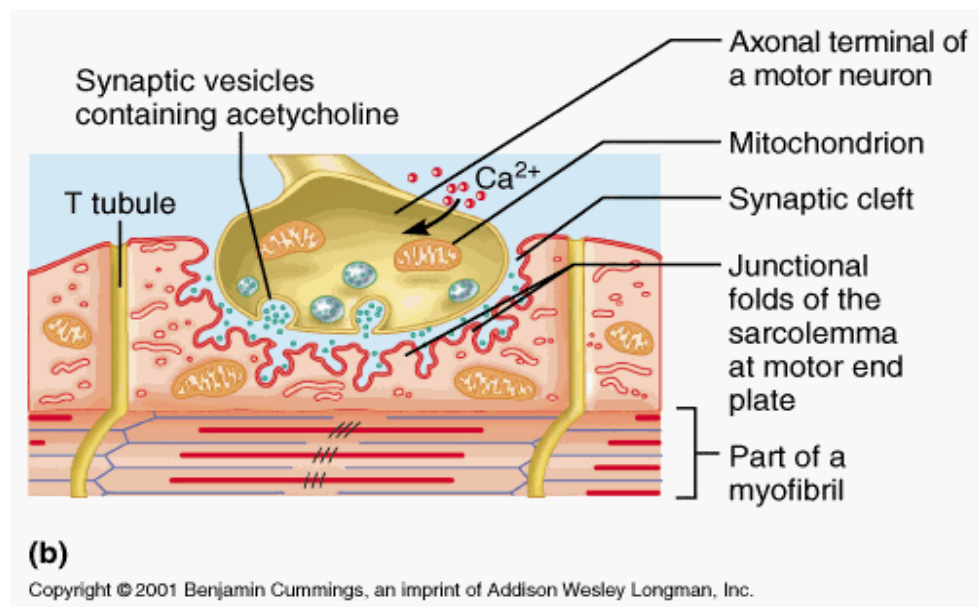

Figure 4. A neuromuscular junction including the vesicles containing acetylcholine and the pre- and post-synaptic membrane. Image from Campbell and Reece, 2005.

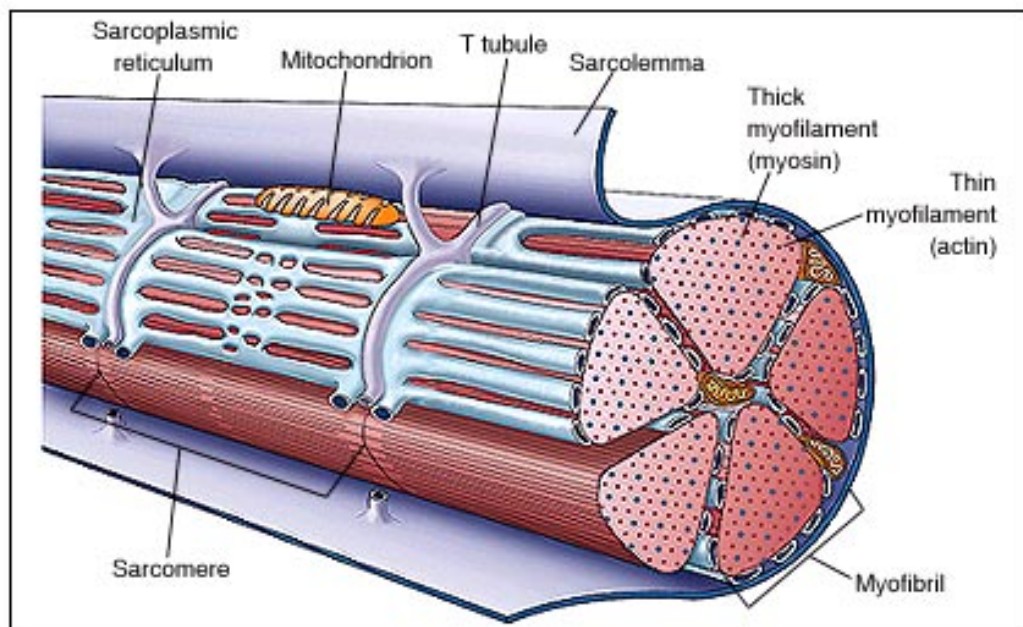

Figure 5. The internal structure of a muscle fiber showing the myofibrils and the mitochondria, sarcolemma and sarcoplasmic reticulum. Taken from Allot and Mindorff, 2007

Electromyography

Electromyography, or the recording/measuring of muscle action potentials, can be used to determine the timing and intensity of muscle recruitment in a living organism (*in vivo*). To do this, surgeries are performed to implant electrodes, which are small and lightweight and in many cases do not affect an animal's behavior or movement. Electromyographic signals (EMGs) allow one to determine the start and end of muscular electrical activity and can provide a general idea as to the relative number of motor units being recruited and the frequency at which they are firing (Figure 6). In this study, bipolar electrodes, with two electrical contacts in the muscle, were used. The implanted electrodes act as an antenna and allow the current from the nerves to flow to an amplifier (Loeb and Gans, 1986). The amplified signals are then filtered and can be graphed using a computer program to show the timing and intensity of the muscle activity signal or EMG (Figure 6).

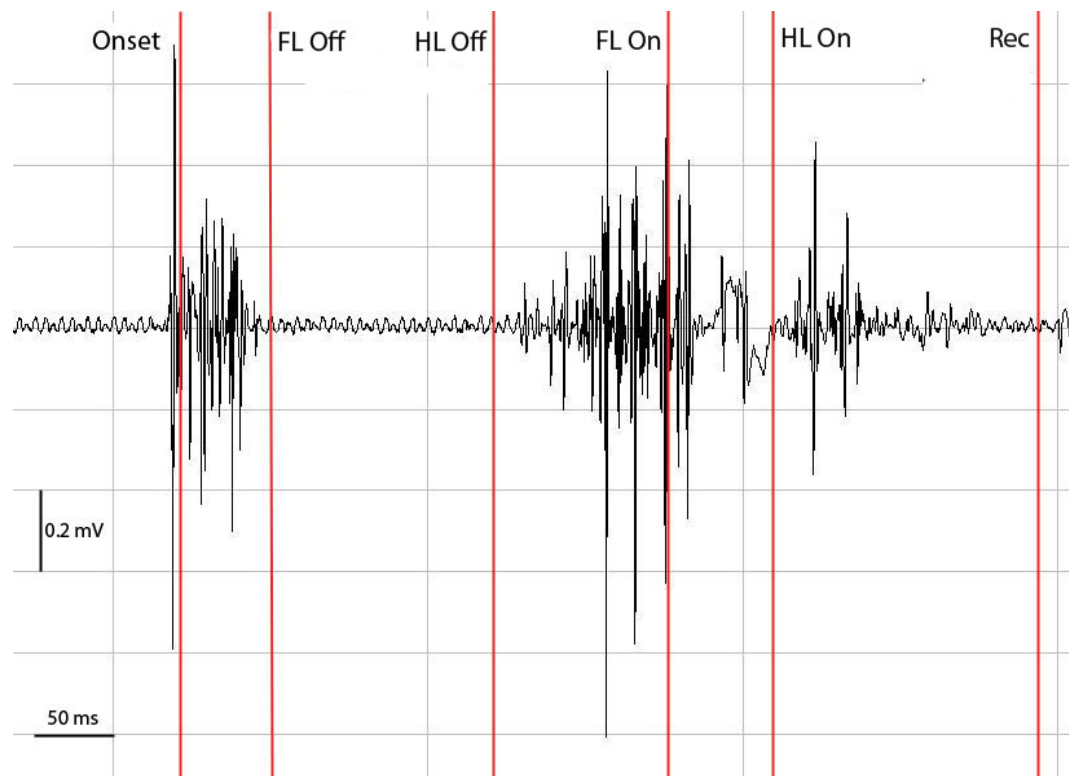

Figure 6. An example of a typical EMG signal obtained from the anconeus muscle of a bullfrog with each part of the jump labeled on the graph. Onset is the time of the start of movement, FL Off is when the forelimbs first leave the ground, HL Off is when the hind limbs first leave the ground, FL On is when the forelimbs return to the ground for landing. HL On is when the hindlimbs touch the ground and recovery is the time after landing where the frog is preparing for the next jump.

Anuran Locomotion

In all anurans, a jump or hop can be divided into four phases: propulsion, flight, landing and recovery (Figure 7) (Nauwelaerts and Aerts, 2005). A jump is a long leap into the air that can carry the animal a distance equivalent to several body lengths. Hopping is very similar to jumping but shorter in distance and movement occurs in many small leaps, instead of one or two longer ones (Wells, 2007). The forelimbs in anurans are much shorter than the hindlimbs and thus provide a relatively short deceleration distance. During a long jump the resulting ground reaction force experienced by the forelimbs during landing is greater than that experienced by the larger hindlimbs at takeoff (Nauwelaerts and Aerts, 2005). This force causes the forelimbs, especially the elbows, to be flexed, as the underlying muscle and tendon absorb the energy of impact. Especially with the larger forces of the longer jumps, this impact compresses the bones of the acromioclavicular pectoral girdle of the frogs placing the coracoid bones in compression while the epicoracoid is held in tension (Emerson, 1983). This pattern of movement gives the frogs greater distance over which to decelerate, and lowers the amount of stress on the frog's forelimb bones (Emerson, 1983).



Onset



Forelimbs Off



Hind Limbs Off



Forelimbs On



Hind Limbs On



Recovery

Figure 7. An image of each part of the jump from the beginning of the propulsion phase to the end of recovery.

Previous research has shown that the cane toad, *B. marinus* (Figure 8), is able to modulate the pre-landing timing and intensity of several muscles in the forelimb, including the anconeus and coracoradialis, prior to impact (Gillis et al., 2010). The anconeus is the major elbow extensor in anurans and has been shown to be recruited approximately 100 ms before the forelimbs touch down during a jump (Gillis et al., 2010). This consistency in the timing before forelimbs touchdown requires changing the timing of the onset of muscle activity depending on the length of the jump since longer hops lead to longer flight phase durations.

In the same study, the coracoradialis, an elbow flexor, as well as the anconeus, the elbow extensor mentioned above, were shown to be recruited at different intensities prior to impact depending on the distance of the jump (Gillis et al., 2010). Specifically, prelanding recruitment intensity in the 50 ms before impact increased with hop distance. These changes in timing and intensity presumably help to allow the toad to land smoothly and safely on the ground after a jump regardless of the distance.

The importance of these muscles in landing in the toad was confirmed through similar research into the more general activity patterns of these muscles. Both the anconeus and coracoradialis show high levels of activity just before and after forelimb touchdown and show considerable overlap in their recruitment patterns, at least in the interval just before and after impact (Akella and Gillis, 2011). The co-recruitment of these muscles during landing suggests that they are

important for stabilizing the elbow joint, preventing it from collapse and allowing the toad to smoothly bring its hind limbs down.

Ranids and Bufonids

Rana catesbeiana is the largest of the North American Ranids, reaching lengths of 5-8 inches; it takes two years to mature from a tadpole (Holmes, 1927). It lives east of the Rocky Mountains, ranging from Mexico into Canada. Its head is generally bright green, but body color can vary from bright green to olive brown, generally with darker spots throughout, especially on the legs (Figure 8). It is never found very far from water, generally staying partially submerged or on the banks of ponds and streams (Holmes, 1927). Bullfrogs are some of the longest anuran jumpers, making leaps of 2-2.5 meters in length (Holmes, 1927)

Rana pipiens, also known as the grass frog, is one of the most common Ranids found in North America. During drier periods these frogs can be found in and around lakes and ponds like many other Ranids (Holmes, 1927). When it is damp and wet though they can be found a great distance from their usual habitats. Their ability to leave the vicinity of the lakes and ponds depends solely on their ability to keep their skin moist in order to breath (Holmes, 1927). They are known to live throughout the United States, more spread out than almost any other Ranid Grass frogs are green with large black splotches throughout that are ringed in white (Holmes, 1927)(Figure 9).



Figure 8. An image of *Rana Catesbeiana* with a bright green head and darker body with spots.



Figure 9. An image of *Rana Pipiens* with its characteristic green coloring with black spots.

Bufo marinus (Figure 10), also known as the cane toad, is the largest species in the genus *Bufo*. It is an invasive species of toad that originated in South America, and is now found throughout the southeastern United States, in Mexico, Puerto Rico, Jamaica and several islands in the West Indies (Noble, 1931) as well as Australia. Cane toads have very warty skin that is generally a brownish green throughout. They are nocturnal, mainly terrestrial animals, living under stones and fallen tree trunks or underground during the day to get out of the sunlight. To protect themselves from predation they have two poison glands (Figure 10) just behind their head that contain a neurotoxin that either kills the predator or renders it weak and paralyzed for a period of time (Noble, 1931).

B. marinus is a member of the family Bufonidae, or true toads, while both Ranid species are members of the Ranidae, or what is known as the true frog family (Figure 11) (Holmes, 1927). Given that the Ranid species are from the same family and share more similar environments, it is likely that they share more traits in common with one another than with *B. marinus*.



Figure 10. An image of *B. Marinus* showing its brown, warty skin and poison glands on the side of its head

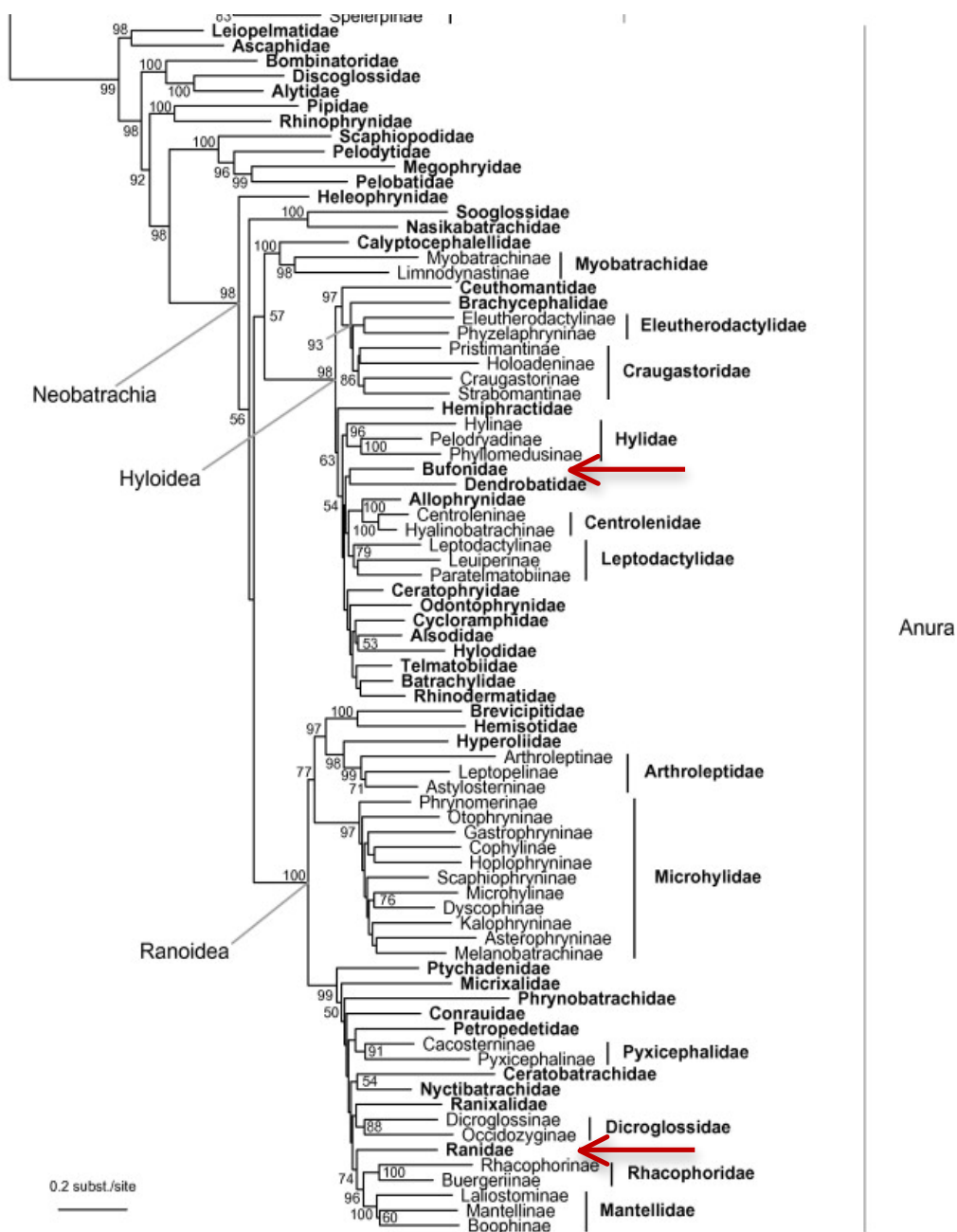

Figure 11. A phylogenetic tree of the different anuran species including the Ranidae, which both *R. Catesbeiana* and *R. Pipiens* belong to, and Bufonidae families, of which *B. Marinus* is a member. Both families are marked with a red arrow. Taken from Pyron and Wiens, 2011)

These relationships (Figure 12) as well as similarities and differences in life history patterns frame some hypotheses for predicting how the muscle recruitment patterns and their modulation will compare between the three species. It is likely that the recruitment patterns seen in *R. catesbeiana* and *R. pipiens* will be very similar to one another. It is less likely that these patterns will resemble those of *B. marinus*, a much more distantly related and more terrestrial species, since being able to land well on land is not nearly as important for an aquatic animal as it is for a terrestrial animal.

In this study I will look at the recruitment patterns of the anconeus and coracoradialis muscles in the grass frog and bullfrog. Focusing on the muscle activity during landing I will look to see how they compare to one another as two closely related species. I will also compare the recruitment patterns found in the grass frog and bullfrog with those of the cane toad, which were looked at previously (Gillis et al., 2010; Akella and Gillis, 2011), to determine how the recruitment patterns found in more aquatic species differ from a more terrestrial species.

MATERIALS AND METHODS

The Animals

For this study four bullfrogs and four grass frogs were obtained from a commercial supplier. The average weight was 58.5g for the bullfrogs and 43g for the grass frogs. They were housed in large plastic bins with three or four animals per bin. In the bin a bowl of water was set out where the animals could bathe in order to keep moist, and plastic huts were provided for the animals to sit under. They were fed medium-sized crickets every day. The room was kept at 25 degrees Celsius and the lights were on a twelve-hour on, twelve-hour off cycle. All experiments were approved by the IACUC committee at Mount Holyoke College.

Osteology

The pectoral girdle of the frog is made up of a series of bones that attach the arm to the thorax. It is made up of the episternum, omosternum, epicoracoid, mesosternum, coracoid, and clavicle (Figure 12). The clavicle and coracoid connect with the scapula of the frog, which in turn articulates with the humerus, creating the shoulder joint (Holmes, 1927). These bones provide attachment points for many of the muscles of the chest and upper arm, including the coracoradialis, which originates at the epicoracoid, and is one of the focal muscles of this study.

The elbow of a frog is defined by the articulation between the humerus and the radio-ulna (Figure 13). The humerus makes up the upper portion of the arm; the radio-ulna underlies the more distal portion of the arm. These bones provide attachment points for many of the muscles of the arm, including the anconeus, which is the other muscle on which this study focuses.

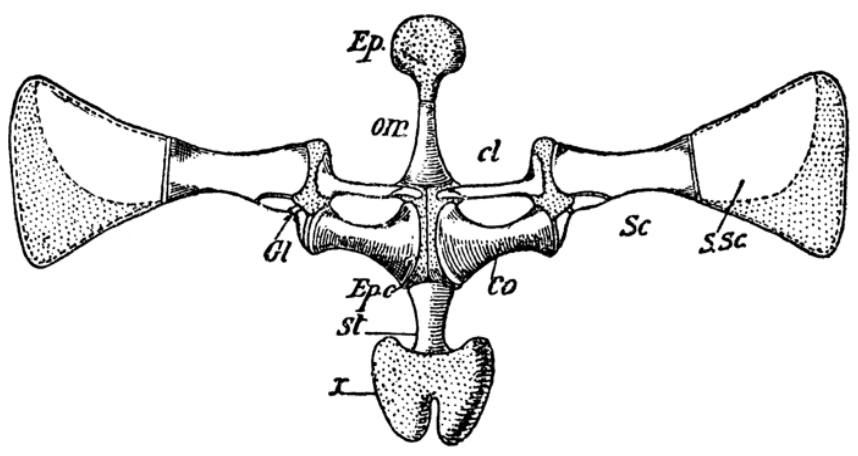

Figure 12. A diagram of the pectoral girdle and sternum of the frog where the muscles of the chest and upper arm originate, including the coracoradialis and anconeus which are the focus of this study. Ep is the episternalis, om is the omosternum, cl is the clavicle, sc and s.sc are the scapula, co is the coracoid, st is the sternum and x is the xiphisternum. Image from Thompson, 1916

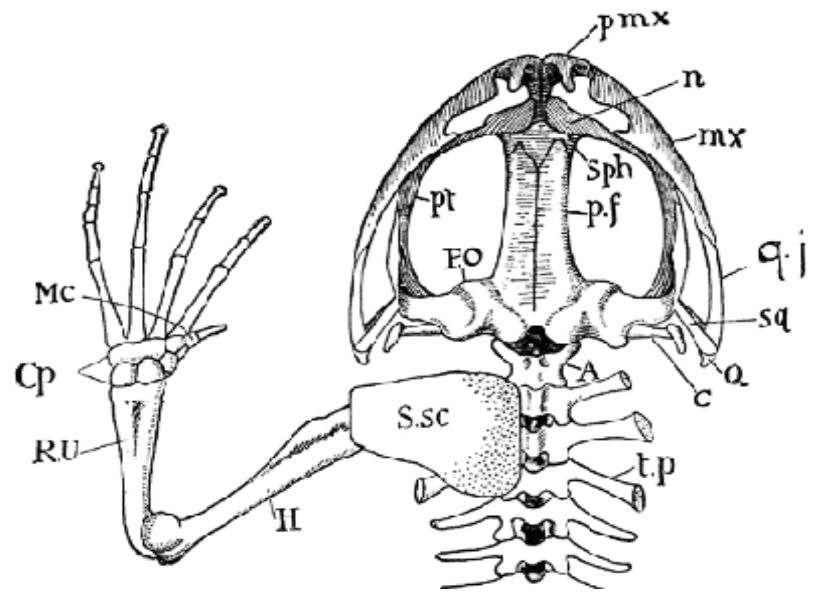

Figure 13. Image of the upper portion of the skeleton of a frog showing the scapula (labeled s.sc), the humerus and the radio-ulna, which are bones to which the anconeus and coracoradialis attach. Image from Thompson, 1916.

Myology

The coracoradialis (Figure 14) is a large elbow flexor that causes the elbow to bend, and along with antagonistic extensor muscles like the anconeus (Figure 15), supports the elbow joint during the landing of a jump. It originates at the episternum and epicoracoid (Figure 12) just under the pectoralis muscles and forms a tendon that connects to the proximal end of the radio-ulna (Figure 13) of the forearm (Ecker, 1889). This tendon allows the muscle to bring the arm in towards the body while also bending the elbow.

The anconeus muscle lies largely on the dorsal surface of the arm (Figure 15); it is made up of three heads. The long head originates from the posterior border of the scapula (Figure 12). The inner or medial head originates on the proximal, medial surface of the humerus (Figure 13), and the outer or lateral head originates from the proximal, lateral surface of the humerus. These unite to form a single tendon, which inserts onto the proximal portion of the radio-ulna (Figure 13) after crossing the elbow joint (Ecker, 1889). These three heads work together to extend the elbow, acting as antagonists to the coracoradialis (Figure 14).

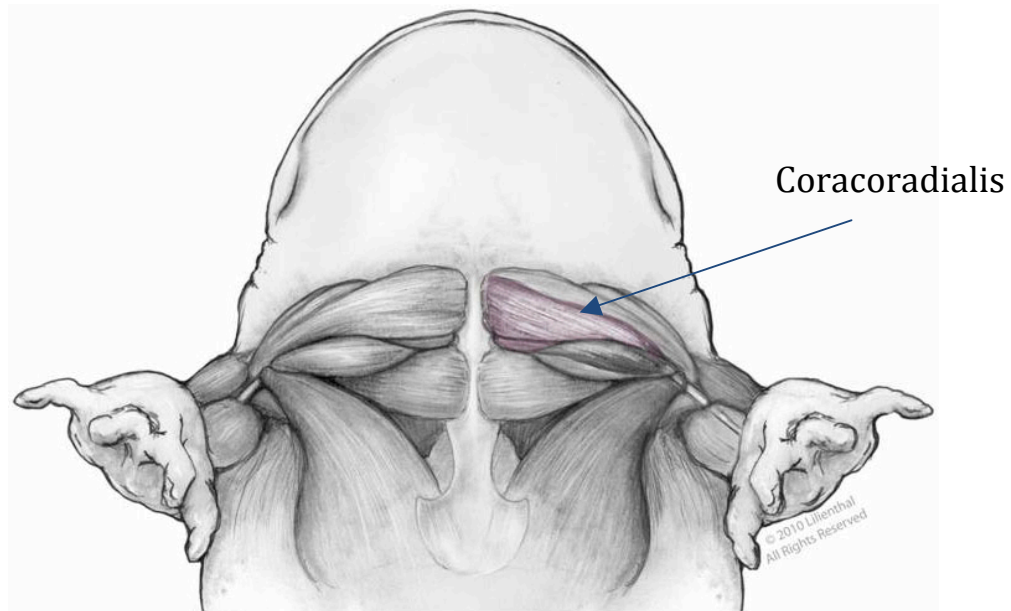

Figure 14. An image of the pectoral muscles of a frog with the left coracoradialis visible after the more superficial pectoralis muscles were removed. Image drawn by Anneliese Lilienthal.

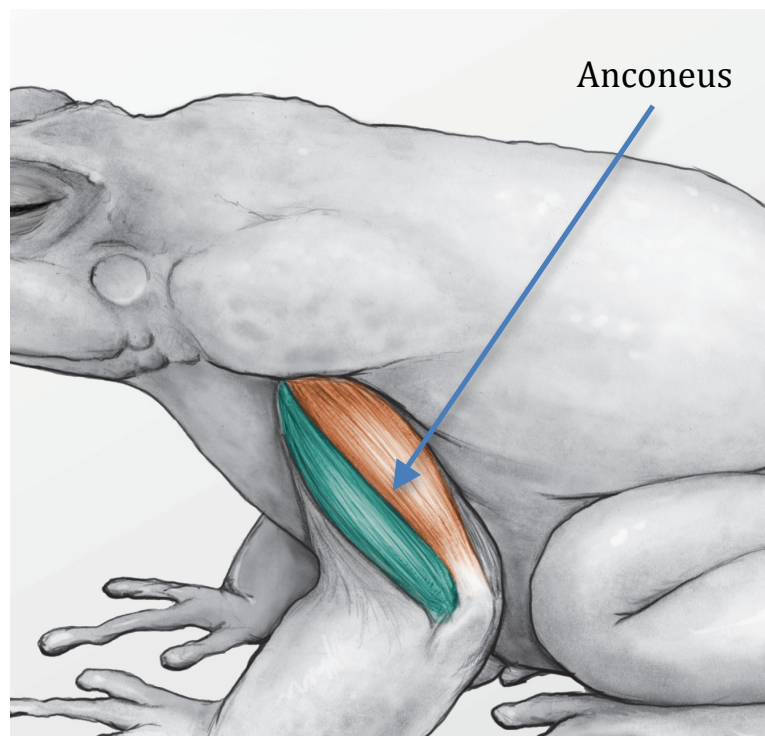

Figure 15. An image with the lateral anconeus muscle visible. Image drawn by Anneliese Lilienthal.

Electrodes

To make the electrodes that were implanted into the muscles of the frog, 0.1mm thick insulated silver wire was used. Two pieces about a meter in length were spun together into a single bipolar electrode. Four electrodes were used per animal to bilaterally implant the coracoradialis and anconeus muscles.

Once an electrode was spun together, about 1mm of insulation was removed from the tips of both wires on one side using a lighter, leaving two exposed ends. The exposed ends were soldered into separate wells in a 15-pin female connector (Figure 16). The tips of the electrodes that would be implanted into the muscle were then bared of insulation until each wire had about 0.5mm exposed; exposed portions were offset to ensure that the two exposed tips could not touch. Once the electrodes were implanted into the muscle of interest the female connector was connected to a complementary male connector. The male connector conducted the signals to amplifiers and ultimately a personal computer where they were visualized and recorded using axoscope software and saved for further analysis.

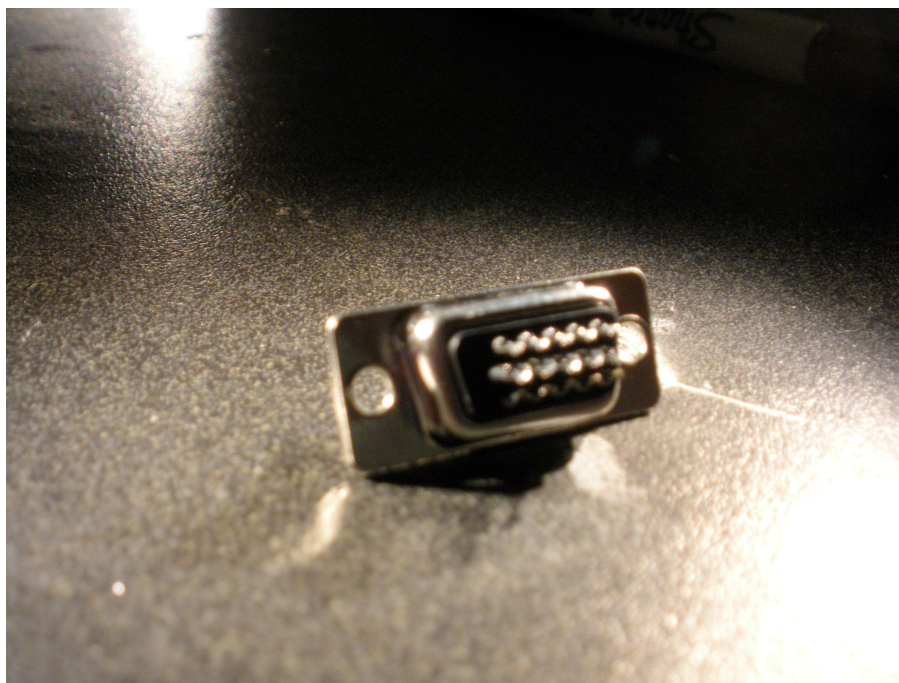

Figure 16. An example of a female connector, into which the electrodes were soldered for this project.

Surgery

The animal was placed in a small plastic tank with a lid to prevent escape. One liter of water was then poured into the tank so that a large portion of the animal was under water. One gram of baking soda along with one gram of the anesthetic tricaine methanesulfonate (MS-222) was then mixed into the water. The animal was left to sit in the water for approximately 10 minutes, until the blink reflex was no longer present.

A small pair of scissors was then used to make the incisions to allow access to the muscles. A 1.5-2 cm incision was made on the lateral portion of each upper arm between the shoulder and the elbow to access the lateral head of the anconeus. A T-shaped incision in the center of the chest was also made in order to access the coracoradialis.

To insert the electrode into the lateral anconeus a 23-gauge needle was used into which the tip of the electrode was inserted forming a small hook. The needle was stuck into the muscle starting proximally near the top of the incision; the electrode was then held in place with a pair of fine forceps while the needle was removed. Insertion was checked by lightly pulling on the electrode to see if it pulled out. When it was secure, the electrode was then sutured in place at the point where it entered the muscle and on the skin right above the incision using 6.0 silk suture. The incision was closed using 4.0 silk suture. To insert the

electrode into the coracoradialis the needle was inserted starting near the midline of the animal and then pushed laterally about 0.5 mm deep into the muscle.

Electrodes were implanted bilaterally in both muscles, and following implantation all four electrodes were glued into one strand using rubber cement. The entire strand was then sutured to the back of the frog twice using 4.0 silk suture. The excess wire near the forelimbs was glued to the skin of the frog using superglue, while still maintaining a full range of arm motion.

The frog was then placed in the jump tank to recover for 1.5-2 hours before jumping trials. If the frog woke up at all during surgery, it was placed back in the anesthetic water for 2 minutes more and surgery was then resumed.

Jumping Trials

Once the frog recovered from surgery and was capable of jumping normally, jumping trials began. The frog was placed in a rectangular (89cm x 43cm x 43cm) glass tank with a portion of a rug covering the bottom to provide traction, and cloth covering the back of the tank to help standardize the background field of view for video recording. The frog was encouraged to jump using loud noises and tapping. Each jump was recorded from a lateral perspective using a digital high-speed video camera with a trigger to stop recording. A 600W light was placed on one side of the tank and positioned to light the entire tank. Fifteen to twenty five jumps were recorded from each animal.

Data Analysis

Jump videos were analyzed using ImageJ software to find the timing of the onset of movement, when the forelimbs left the ground, when the hind limbs left the ground, when the forelimbs touched the ground, when the hind limbs touched the ground, and the point of recovery, when the animal appeared ready to jump again. These timing data were entered into an Excel spreadsheet. The electromyography (EMG) data were analyzed using axoscope software. The time of the trigger was recorded to allow synchronization of the EMG and video data. The timing of EMG events was analyzed in the context of the behavioral data obtained from ImageJ.

From these data we were able to determine whether bursts of muscle activity were associated with the takeoff portion of the jump or the landing. The timing of the start of each burst was recorded in an Excel spreadsheet and the information was used to calculate the time between the start of the jump and the onset of muscle activity (onset latency) of each muscle during the jump. The pre-landing signal intensity, or average voltage of each EMG signal during the 50ms before the forelimbs touched down, was also calculated using Axoscope and Excel. These data were then plotted against hop distance and linear regressions were used to look for any trends between the onset latency and pre-landing recruitment with the hop distance. Trends were considered significant if $P < 0.05$ for each relationship.

To see if there were any general trends in the timing of the different parts of the jump with respect to the activity of the muscle, binning was done using Axoscope and Excel. To do this the Axoscope data from the time of forelimb off to the time of recovery were copied into an Excel document. A macro was then used to split the jump into 100 equal parts and average the signal voltage during each interval. The bins from all of the jumps from one frog were then averaged and a bar graph of the data was created that showed the profile of the muscle recruitment during the jump. The timing of hind limbs coming off the ground, as well as the timing of when the forelimbs and hind limbs touched the ground on landing were mapped onto this graph (Figure 17). The graphs from each frog were then compared to see if there were any similarities in the timing of certain events with respect to the burst of muscle activity.

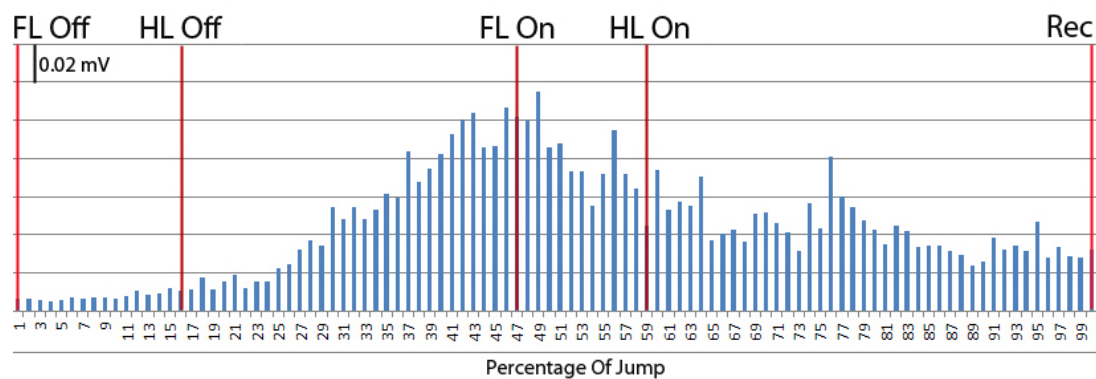

Figure 17. An example of a binning graph with each bin representing an average from all of the jumps from that frog onto which the average timing of certain events during the jump was mapped.

RESULTS

Kinematics

In the grass frogs, hop distances varied depending on the animal. In two of the frogs, the range of distances observed spanned only 20-24 cm, whereas in the other two, distances ranged over 30 cm. (Table 1). One frog also jumped much farther, on average, than the other three (Table 1).

Table 1. Hop data recorded from grass frogs.

Frog	Number of Hops	Distance (cm)
1	24	Range: 33-57 Average: 48
2	24	Range: 13-53 Average: 35
3	23	Range: 13-44 Average: 33
4	24	Range: 15-35 Average: 23

Variation in the range of jump distances was also present among the bullfrogs studied. Two animals had a very narrow range of hop distances, spanning 13-23 cm, while the other two animals hopped distances spanning over 30 cm. (Table 2). The animals that demonstrated the greater range of distances also jumped farther, on average, than the frogs with the smaller range of distances (Table 2).

Table 2. Hop data recorded from bullfrogs.

Frog	Number of Hops	Distance (cm)
1	14	Range:15 -57 Average: 43
2	22	Range: 23-67 Average: 43
3	18	Range:12-35 Average: 27
4	14	Range: 18-31 Average: 25

In both the grass frogs and the bullfrogs, the proportion of time spent in each phase of the hop was nearly identical. For example, the propulsive phase, during which the frogs use their legs to propel themselves in the air, took up about 30 % of the jump in both species. This phase lasted about 250 ms in the grass frogs (Figure 18, Figure 19a) and 150 ms in the bullfrogs (Figure 18, Figure 19b). During the aerial phase the frogs brought their arms forward in preparation for landing and began to fold their legs up underneath their body (Figure 18). The duration of this phase occupied 25% of the jump in both species (Fig. 18) and increased with increasing hop distance, indicating that the frog spent more time in the air for the longer jumps (Figure 20). During landing the grass frogs tended to have their legs splayed out behind them, requiring more recovery time than the bullfrogs, which were able to land with their legs more underneath the body

(Figure 18). The duration of the landing phase in both species varied considerably, ranging from 100 ms to 400 ms but consistently occupied about 40% of the jump in both species (Figure 21).

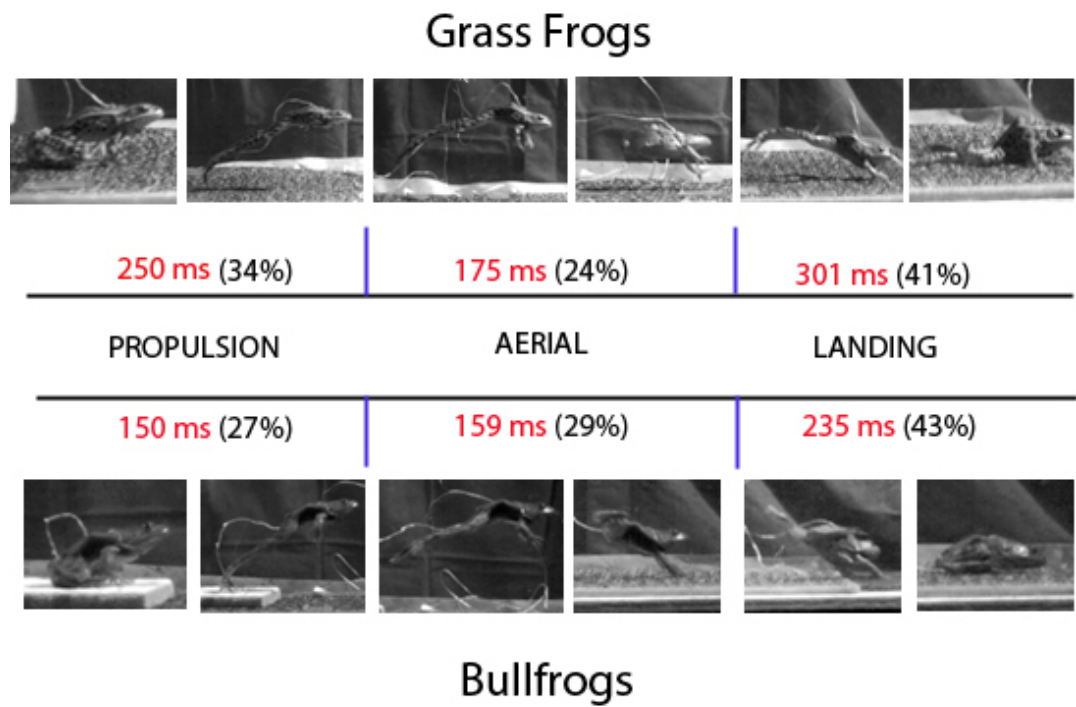

Figure 18. The timing of an average jump in grassfrogs and bullfrogs.

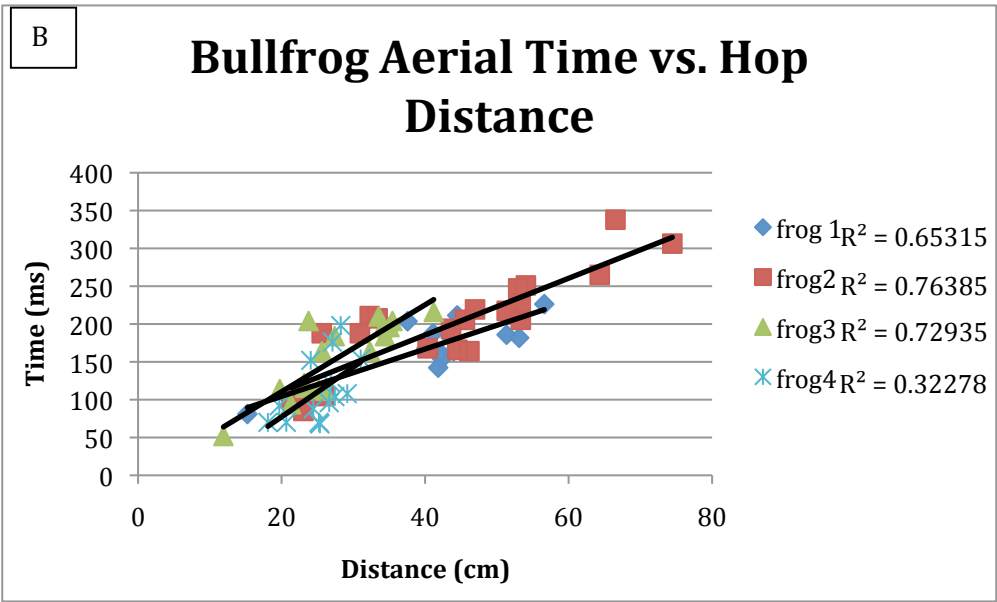
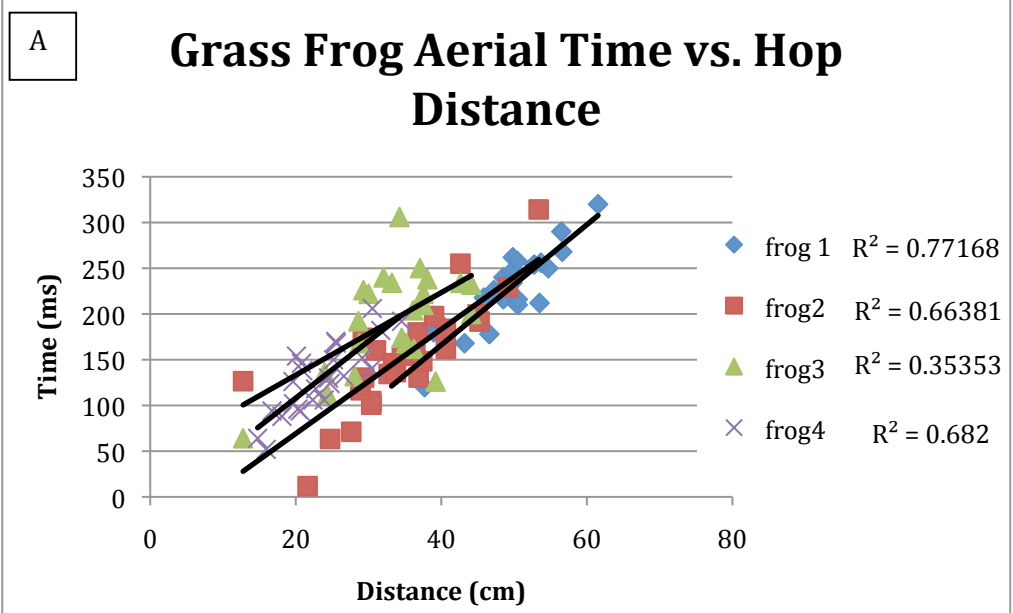

Figure 20. A. Aerial time as a function of hop distance in grass frogs. B. Aerial time as a function of hop distance in bullfrogs.

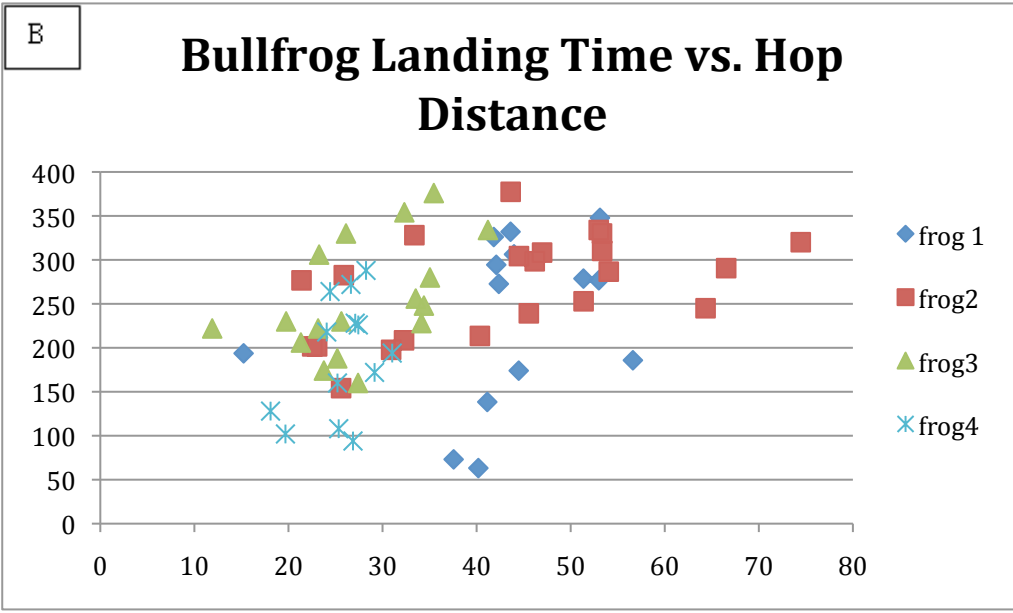
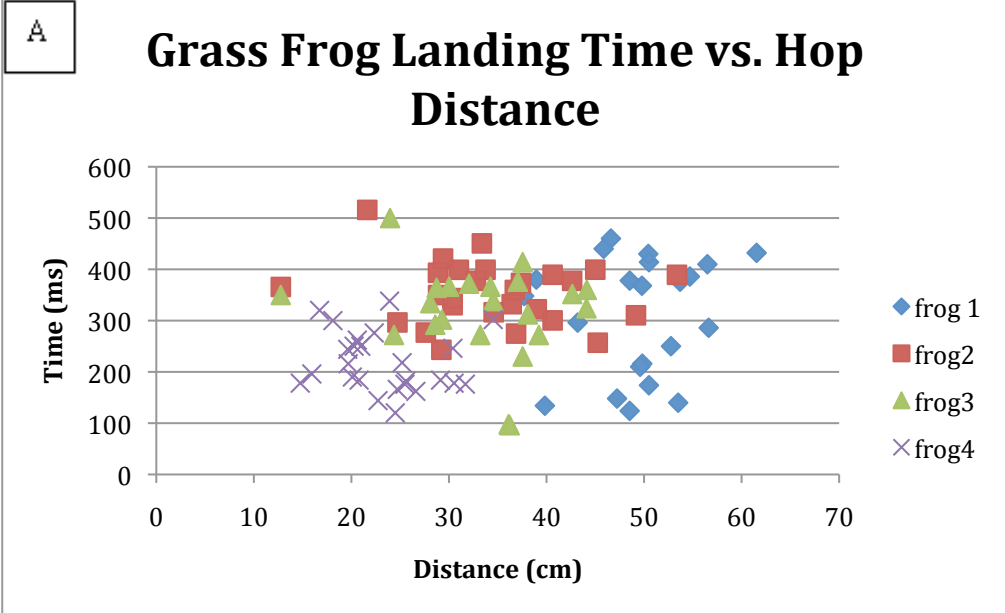

Figure 21. A. Landing time as a function of hop distance in grass frogs. B. Landing time as a function of hop distance in bullfrogs.

Muscle Recruitment Patterns

In the grass frogs there was one main burst of coracoradialis activity during a jump. It generally started just before the hindlimbs left the ground and ended shortly after the hindlimbs touched down; maximum intensities were typically observed shortly before impact (Figure 22).

As in the grass frogs, the bullfrogs also exhibited one main burst of coracoradialis activity during a jump. Activity onset generally began near the time of takeoff (Figure 23), although in some jumps it didn't begin until well after takeoff. Intensities of muscle activity tended to increase until just before forelimb touchdown, and activity ended shortly after landing, before the frog had fully recovered from the jump (Figure 23).

The anconeus in the grass frog had two separate bursts of activity, one associated with takeoff and the other with landing. The burst associated with takeoff typically began just before the onset of movement and ended just before the forelimbs left the ground (Figures 24 and 25). The second burst of activity began shortly after the hindlimbs left the ground and ended soon after the hindlimbs touched the ground at landing (Figure 25). In three out of the four grass frogs, the timing of the forelimbs touching the ground coincided with the peak of anconeus recruitment.

The anconeus of the bullfrogs also exhibited two separate bursts of activity during the jump. In the burst associated with takeoff, activity started just

before the onset of movement and ended shortly before the forelimbs came off the ground (Figures 26 and 27). The second burst of activity started shortly after the hindlimbs came off the ground and ended just after the hindlimbs touched the ground after landing (Figure 27). In all four bullfrogs the peak of muscle activity occurred very near forelimb touch down (Figures 26 and 27).

A.

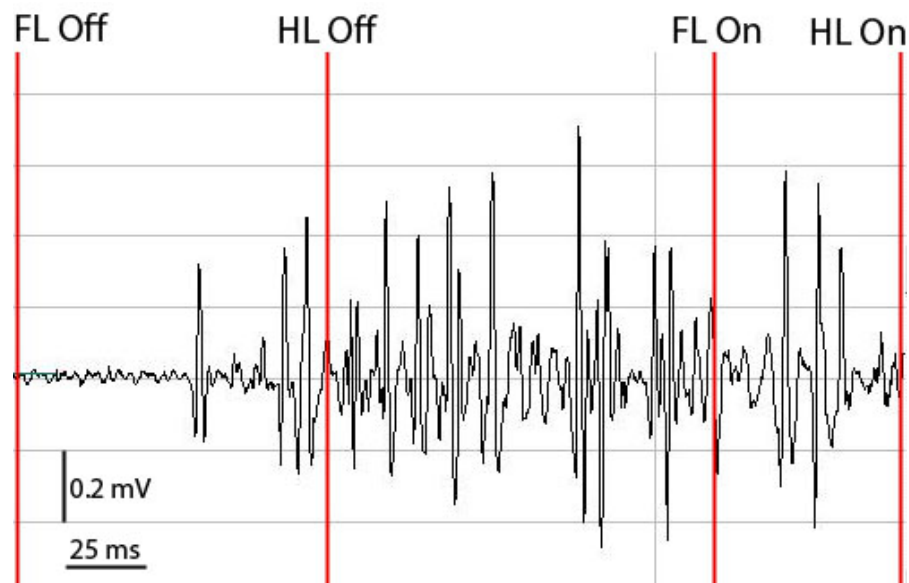

B.

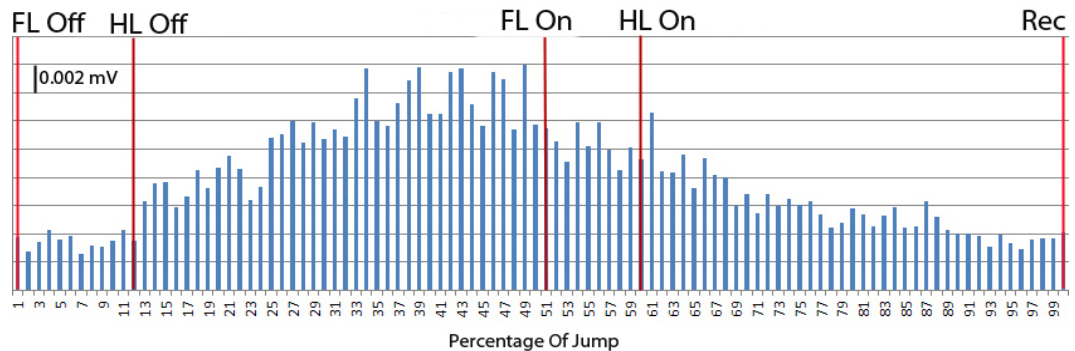
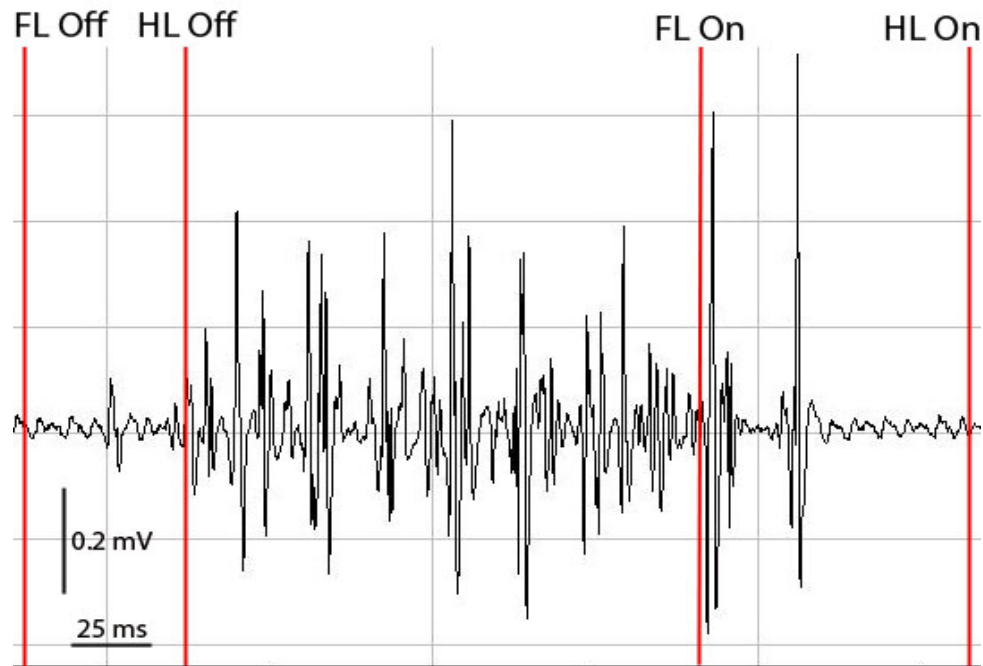

Figure 22. A. Representative EMG signal from the coracoradialis muscle of a grass frog with the timing of important kinematic events mapped on. B. A binning profile averaging the signal intensity of all of the jumps from one frog with the timing of important kinematic events mapped on. Onset is when the animal begins to move during a jump; FL Off is when the forelimbs leave the ground; HL Off is when the hind limbs leave the ground; FL On is when the forelimbs touch the ground; HL On is when the hind limbs touch the ground, and Rec is when the frog has fully recovered and is ready to jump again.

A.



B.

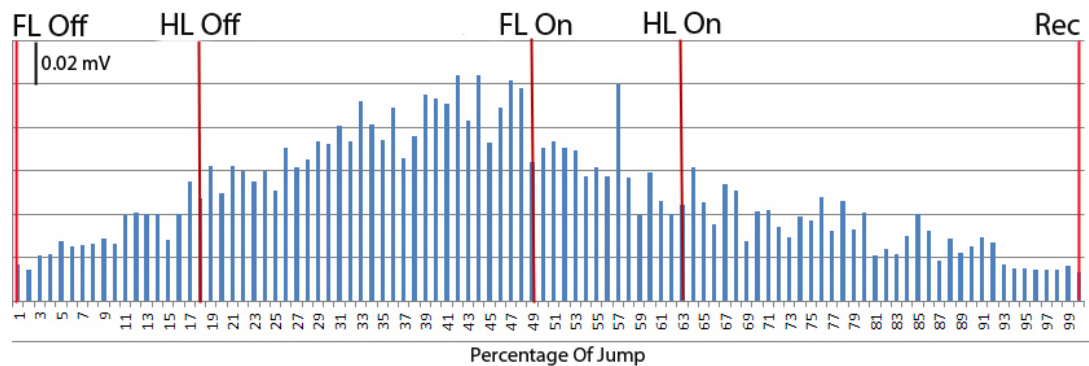

Figure 23. A. A representative EMG signal from the coracoradialis muscle of a bullfrog with the timing of each event mapped on B. An example binning graph of the average of all of the jumps from one frog to show what the jumps are like in general with the timing of specific events mapped on. Onset is when the animal begins to move during a jump; FL Off is when the forelimbs leave the ground; HL Off is when the hind limbs leave the ground; FL On is when the forelimbs touch the ground; HL On is when the hind limbs touch the ground, and Rec is when the frog has fully recovered and is ready to jump again.

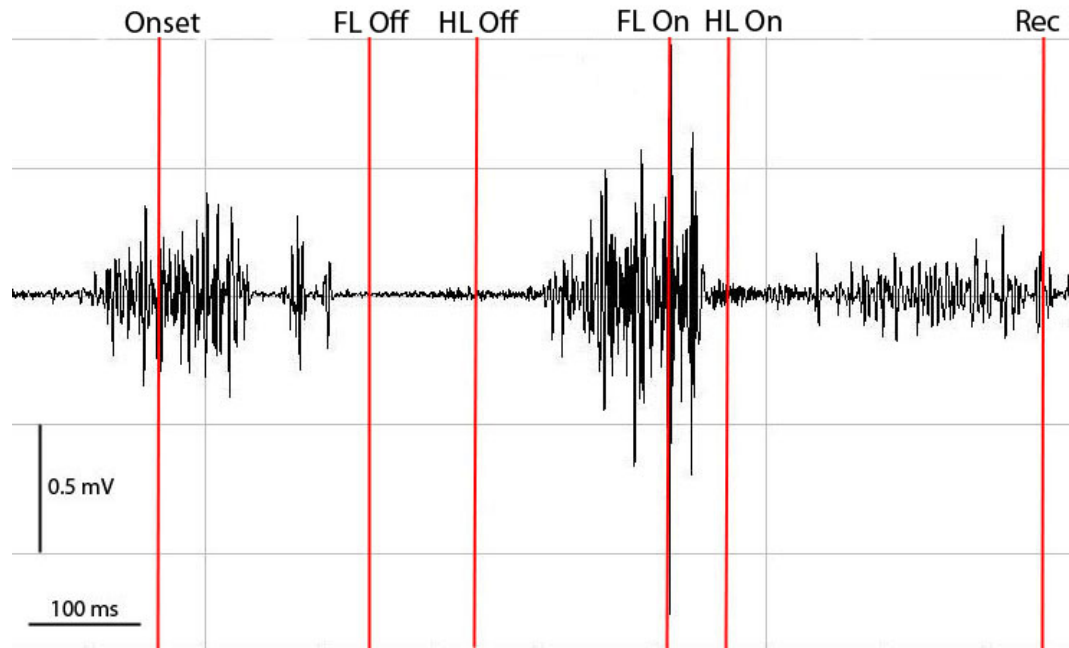
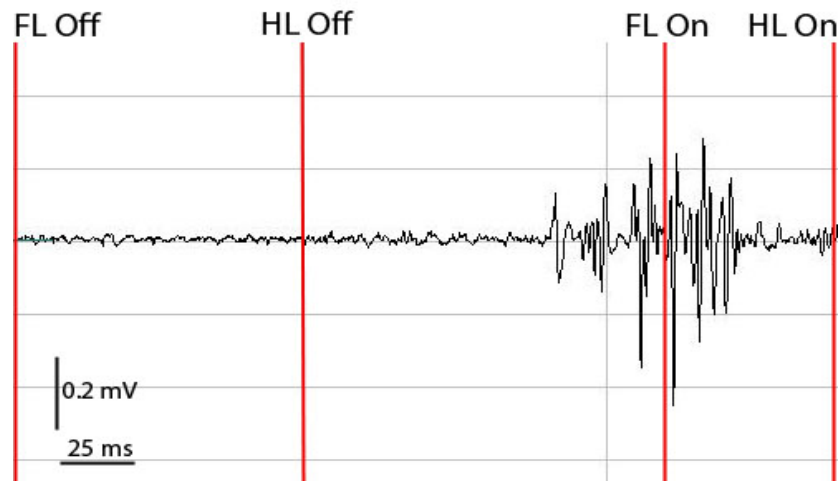

Figure 24. A representative EMG signal from the anconeus muscle of a grass frog from onset of activity to recovery onto which the timing of each event was mapped

A.



B.

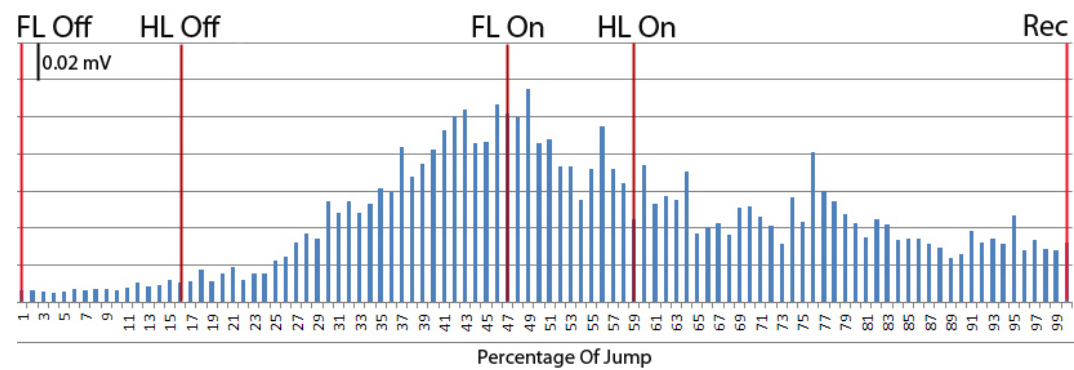

Figure 25. A. A representative EMG signal from the anconeus muscle of a grass frog with the timing of each event mapped on B. An example binning graph of the average of all of the jumps from one frog to show what the jumps are like in general with the timing of specific events mapped on. Onset is when the animal begins to move during a jump; FL Off is when the forelimbs leave the ground; HL Off is when the hind limbs leave the ground; FL On is when the forelimbs touch the ground; HL On is when the hind limbs touch the ground, and Rec is when the frog has fully recovered and is ready to jump again.

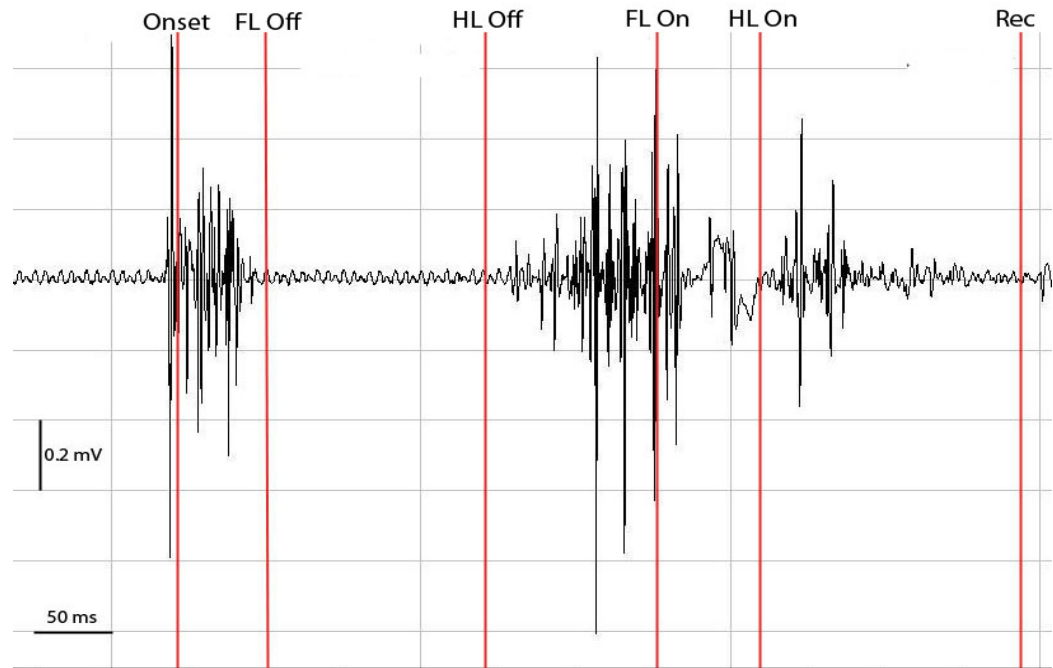
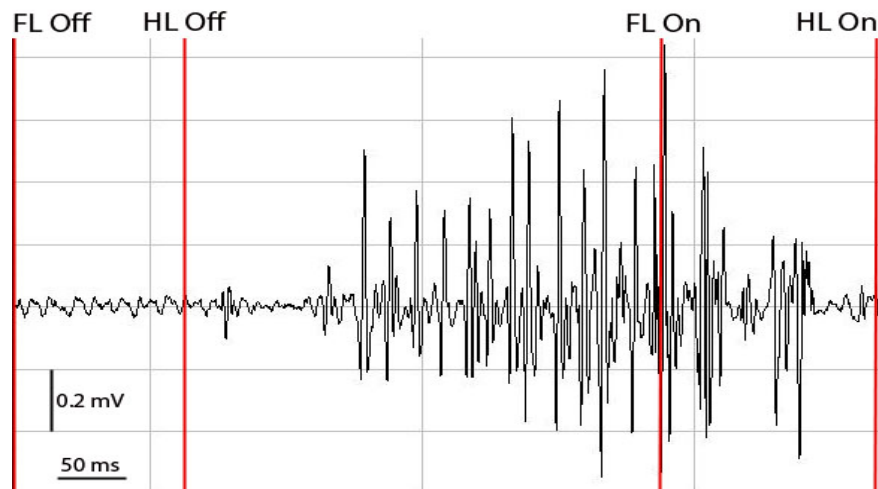

Figure 26. A representative EMG signal from the anconeus muscle of a bullfrog from the onset of movement onto which the timing of each event was mapped.

A.



B.

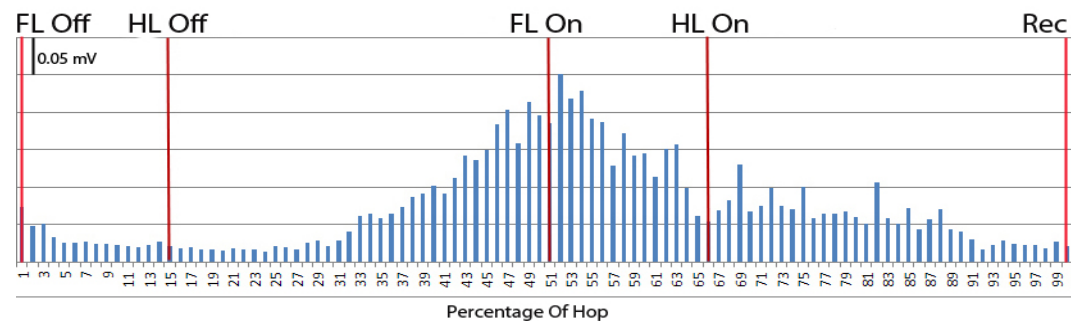

Figure 27. A. A representative EMG signal from the anconeus muscle of a bullfrog with the timing of each event mapped on B. An example binning graph of the average of all of the jumps from one frog to show what the jumps are like in general with the timing of specific events mapped on. Onset is when the animal begins to move during a jump; FL Off is when the forelimbs leave the ground; HL Off is when the hind limbs leave the ground; FL On is when the forlimbs touch the ground; HL On is when the hind limbs touch the ground, and Rec is when the frog has fully recovered and is ready to jump again.

Coracoradialis

The onset latency of the coracoradialis increased significantly with jump distance in one of the four grass frogs (Figure 28a) and in one of the four bullfrogs (Figure 28b). These animals in which significant trends were found had relatively large ranges of hop distance compared to the other animals (Figure 28). A significant positive trend was also seen in both the grass frogs and bullfrogs when all of the jumps were combined. A significant positive relationship for this variable indicates that animals activate the coracoradialis later for the longer jumps than for the shorter jumps. The timing of onset of recruitment with respect to the timing of the forelimbs is also generally consistent, about 150 ms before in grass frogs and 200 ms in bullfrogs

The average pre-landing intensity of the coracoradialis muscle increased with increasing hop distance in two out of the four grass frogs (Figure 29a) and in two out of the four bullfrogs (Figure 29b). In both species one of these animals was also the frog that displayed a significant trend in onset latency (Figure 28). The frogs in which there was not a significant trend tended to have smaller ranges in hop distance (Figure 29). A significant trend in this variable indicates that the coracoradialis muscle was recruited in a distance-dependent manner.

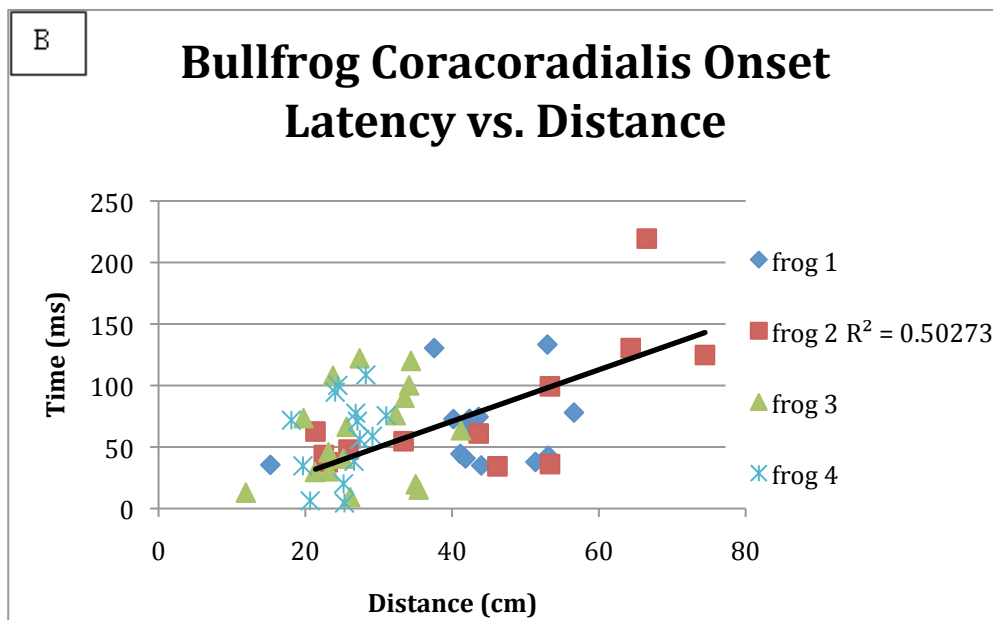
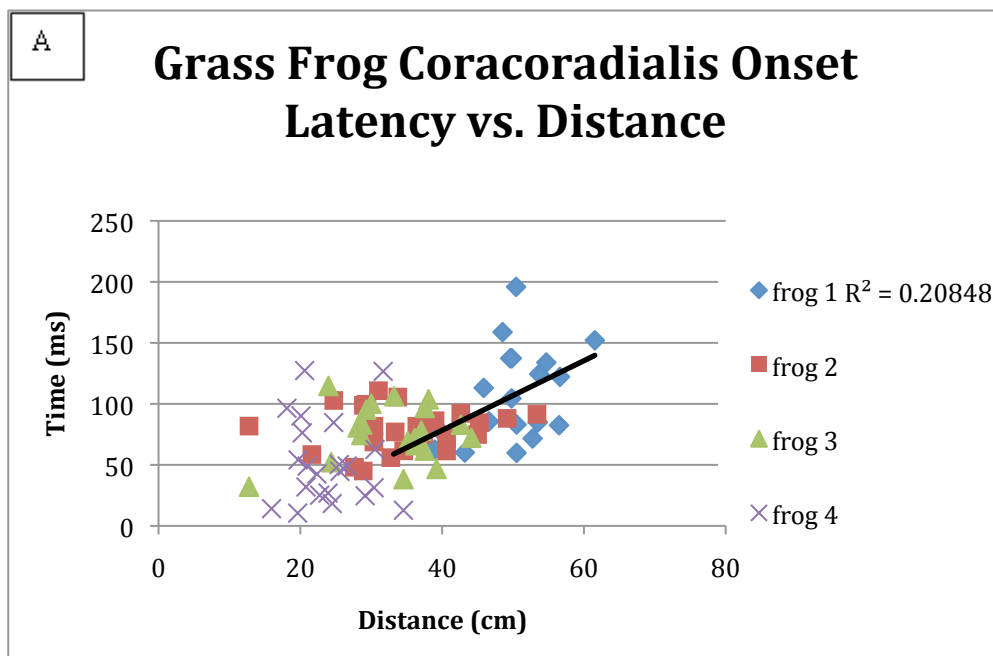

Figure 28. A. Coracoradialis onset latency as a function of hop distance in grass frogs. B. Onset latency as a function of hop distance in bullfrogs. Different symbols represent different animals and regression lines represent relationships in which the slope is significantly different from zero.

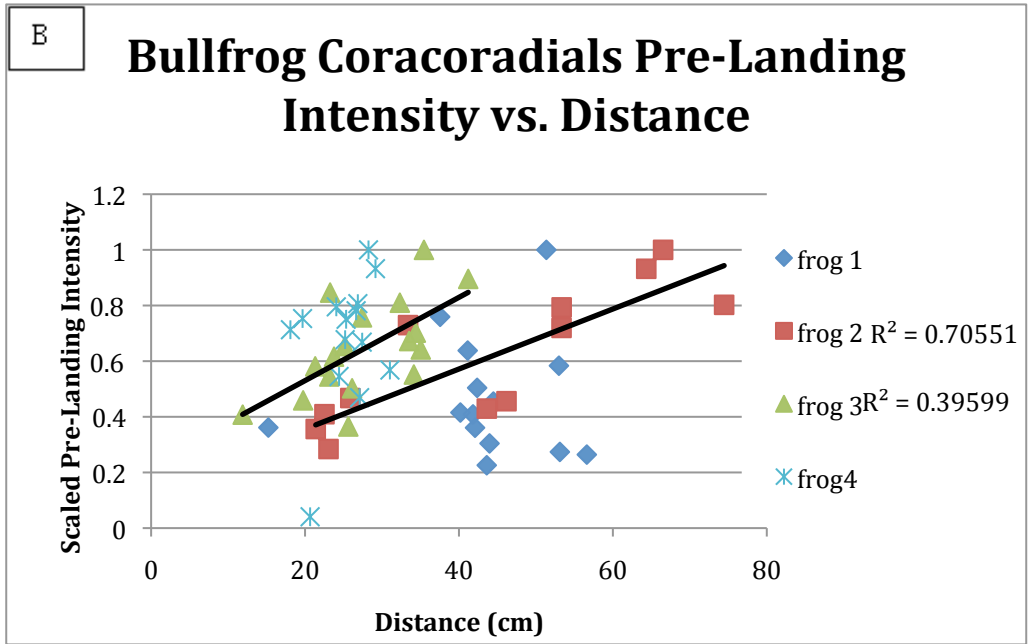
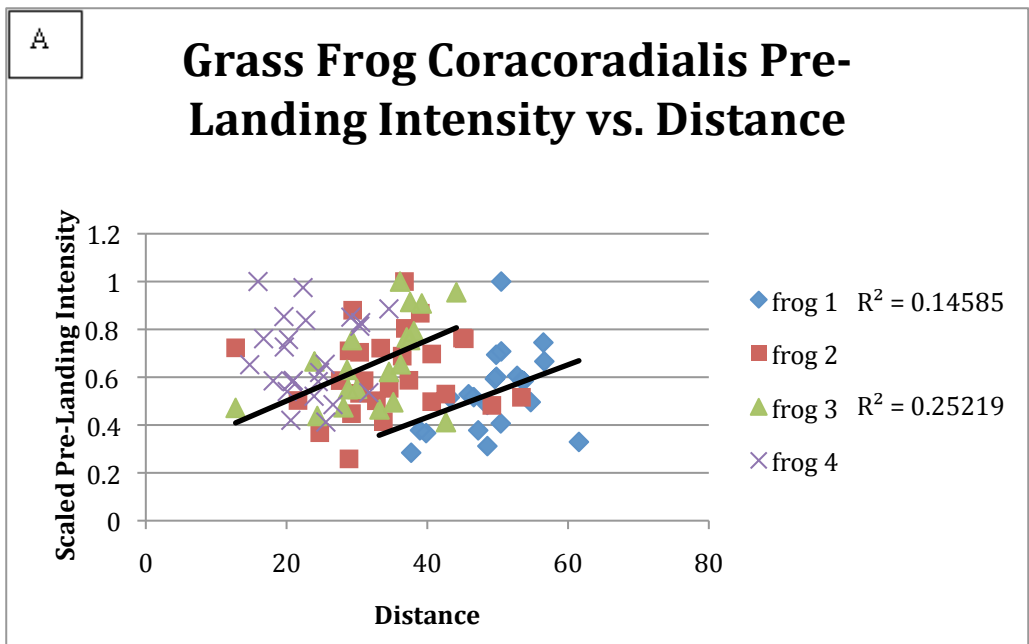

Figure 29. A. Coracoradialis pre-landing intensity as a function of hop distance in grass frogs. B. Coracoradialis pre-landing intensity as a function of hop distance in bullfrogs. Different symbols represent different animals and regression lines represent relationships in which the slope is significantly different from zero. The voltages have been scaled relative to the maximum value seen in each value

Anconeus

The onset latency of the anconeus increased significantly with hop distance in two out of the four grass frogs (Figure 30a) and in two out of the four bullfrogs (Figure 30b). In both species, one of the two frogs with a significant trend also showed a significant trend in the onset latency of the coracoradialis. The frogs in which there was not a significant trend were those with the smallest range in hop distances (Figure 30). A significant positive trend was also seen when all of the jumps in each species were combined. The timing of onset with respect to the forelimbs touching the ground was also consistent, about 110 ms before in the grass frogs and 125 ms before in the bullfrogs.

The pre-landing intensity of the anconeus muscle increased significantly with jump distance in three out of the four grass frogs (Figure 31a) and in two out of the four bullfrogs (Figure 31b). One out of the three grass frogs and one out of the two bullfrogs that had a significant trend also showed a significant trend in the onset latency of the anconeus muscle. The frogs in which there was not a significant trend tended to have smaller ranges in hop distance.

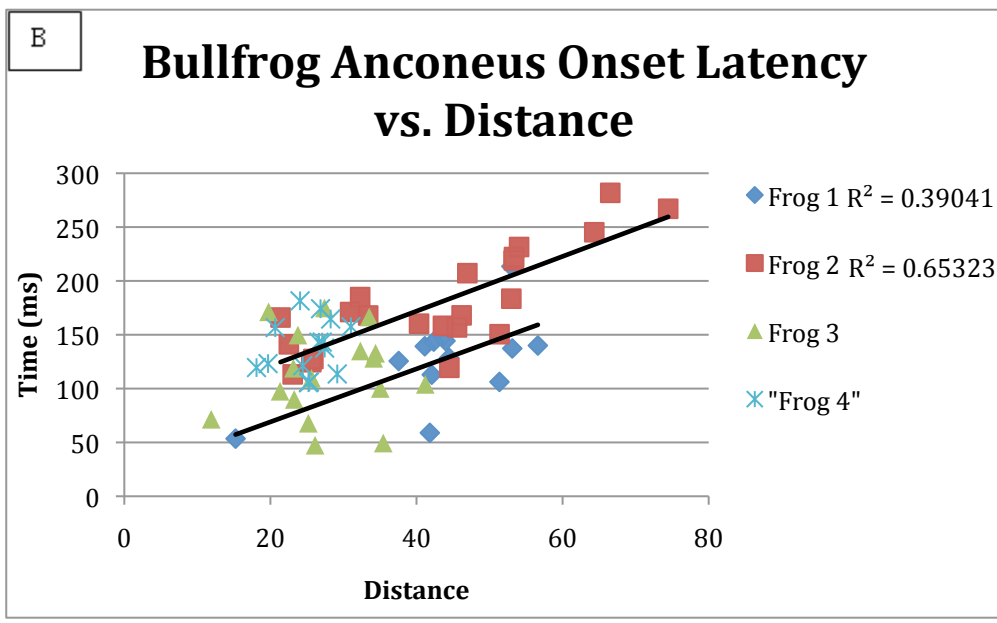
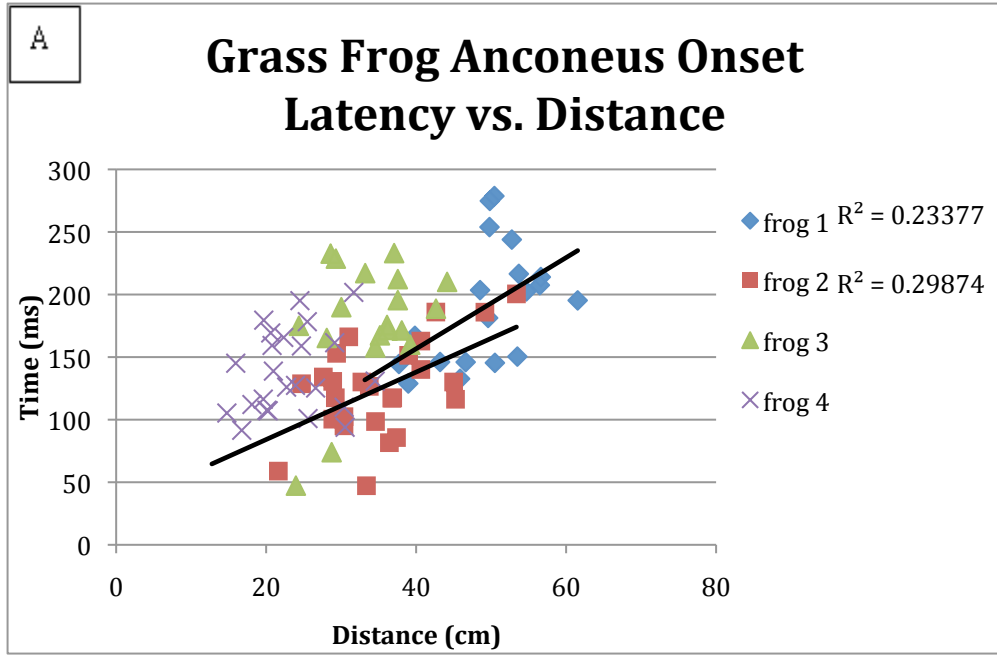

Figure 30. A. Anconeus onset latency as a function of hop distance in grass frogs. B. Anconeus onset latency as a function of hop distance in bullfrogs. Different symbols represent different animals and regression lines represent relationships in which the slope is significantly different from zero.

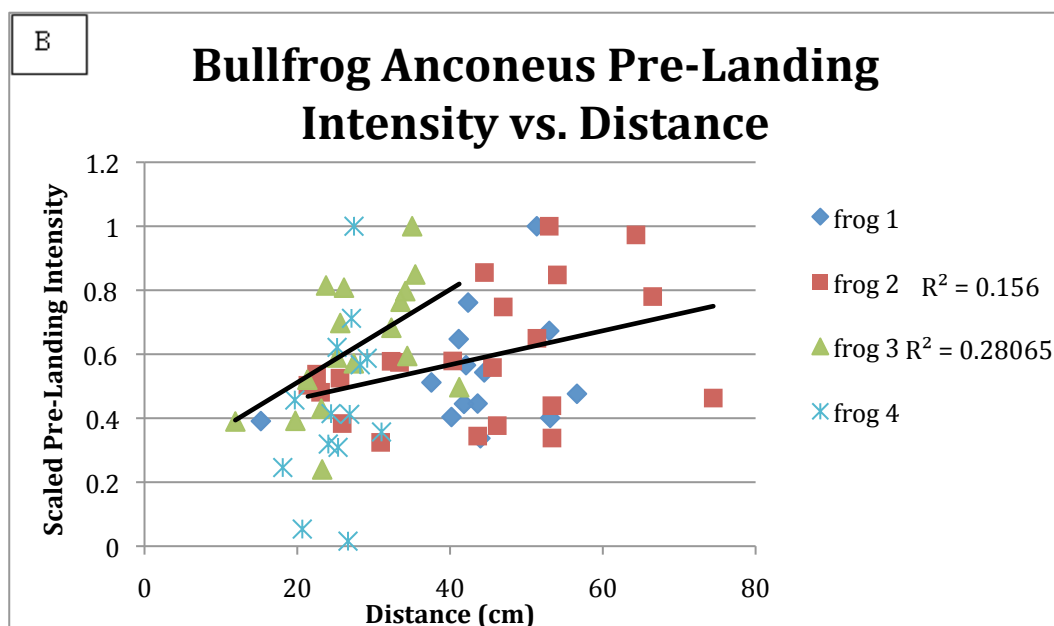
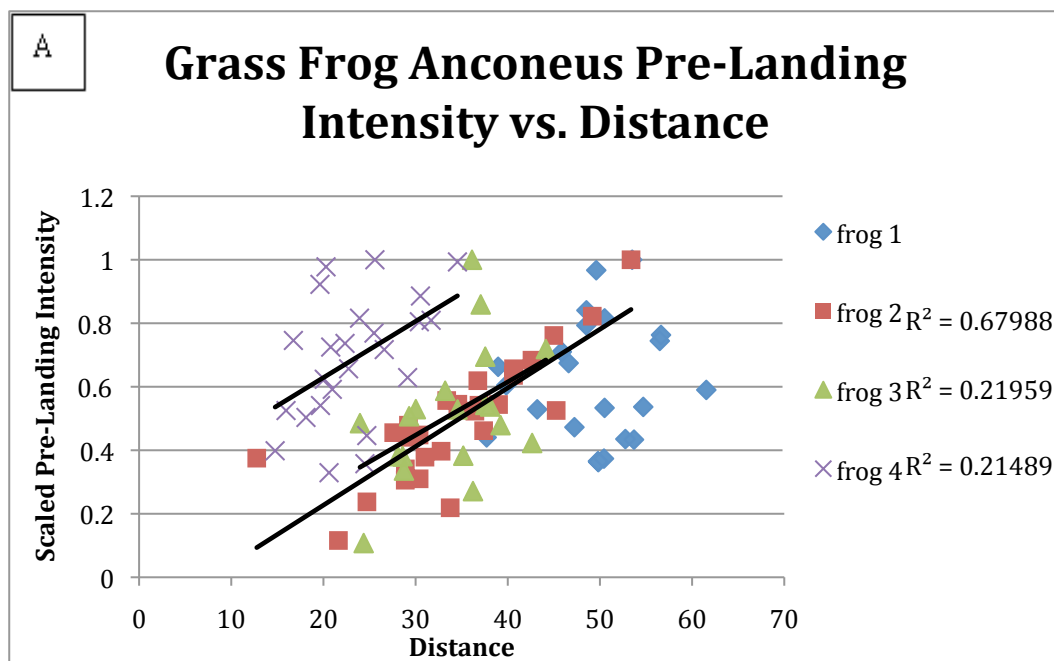

Figure 31. A. *Anconeus* pre-landing intensity as a function of hop distance in grass frogs. B. *Anconeus* pre-landing intensity as a function of hop distance in bullfrogs. Different symbols represent different animals and regression lines represent relationships in which the slope is significantly different from zero. Values are scaled relative to the maximum voltage seen in each animal.

Discussion

The results of this experiment show that muscle recruitment patterns in grass frogs and bullfrogs are more similar to one another than they are to cane toads, as predicted from their closer phylogenetic relationship. Indeed, patterns seen in the bullfrog and grass frog were nearly identical despite observed differences in their landing abilities.

Kinematics

While the basic kinematics of the jump are very similar in all three anuran species, the percentage of the jump spent in each phase does vary. Bullfrogs spend about a quarter of the jump in the propulsive phase; grass frogs spend about a third of the jump in this phase, and cane toads spend about half of the jump in propulsion (Akella and Gillis, 2011). The aerial phase of the grass frogs and bullfrogs takes up about a quarter of the jump, but in cane toads the aerial phase makes up only about fifteen percent of the jump (Akella and Gillis, 2011). The toads also spend less time in landing and recovery than the frogs, indicating their capacity for better coordinating impact and being ready to hop again sooner.

At least some of these differences in the percentage of time spent in each phase of the jump are likely due to the fact that toads typically jump shorter distances than ranid frogs. The average jump distance in the grass frogs and bullfrogs studied here was about 35 cm while the average jump distance in a

previous study of cane toads was about 27 cm (Akella and Gillis, 2011). With shorter hop distances, the time spent in the air is shorter than in longer jumps (this study figure 20, Akella and Gillis, 2011); so if the timing of the take-off and landing phases stay about the same, the percentage of the jump spent in the air will be smaller. It is likely that if toads were to hop distances closer to those seen in the frogs, the percentage of time spent in the air would be closer to that seen in the frogs.

Muscle Activity Patterns

The recruitment patterns of the coracoradialis in the grass frogs and bullfrogs were somewhat different from those seen in the cane toads. In the grass frogs and bullfrogs there is one burst of muscle activity that generally starts between 75-100 ms after the forelimbs leave the ground. In the cane toads the onset of coracoradialis recruitment is consistently about the time the forelimbs leave the ground (Akella and Gillis, 2011).

The earlier recruitment of the coracoradialis, an elbow flexor, allows the toads to bring their arms up and forward earlier in the hop than the grass frogs and bullfrogs (Figure 32). These results suggest that toads prepare earlier for landing than the grass frogs and bullfrogs, as they begin to recruit this muscle even before they take off into the air (Figure 32). Perhaps this is a factor underlying why cane toads exhibit much more controlled landings (Gillis et al., 2010; Akella and Gillis,

2011). However, since the grass frogs and bullfrogs are jumping longer distances than the cane toad, they are in the air longer and may not need to prepare for landing as early.

The anconeus muscle, like the coracoradialis, is recruited later in the jump in grass frogs and bullfrogs than it is in cane toads (Figure 33). Anconeus muscle recruitment begins after the hind limbs leave the ground in the ranids, but in the cane toads recruitment begins just before the hind limbs leave the ground (Figure 31) (Akella and Gillis, 2011).

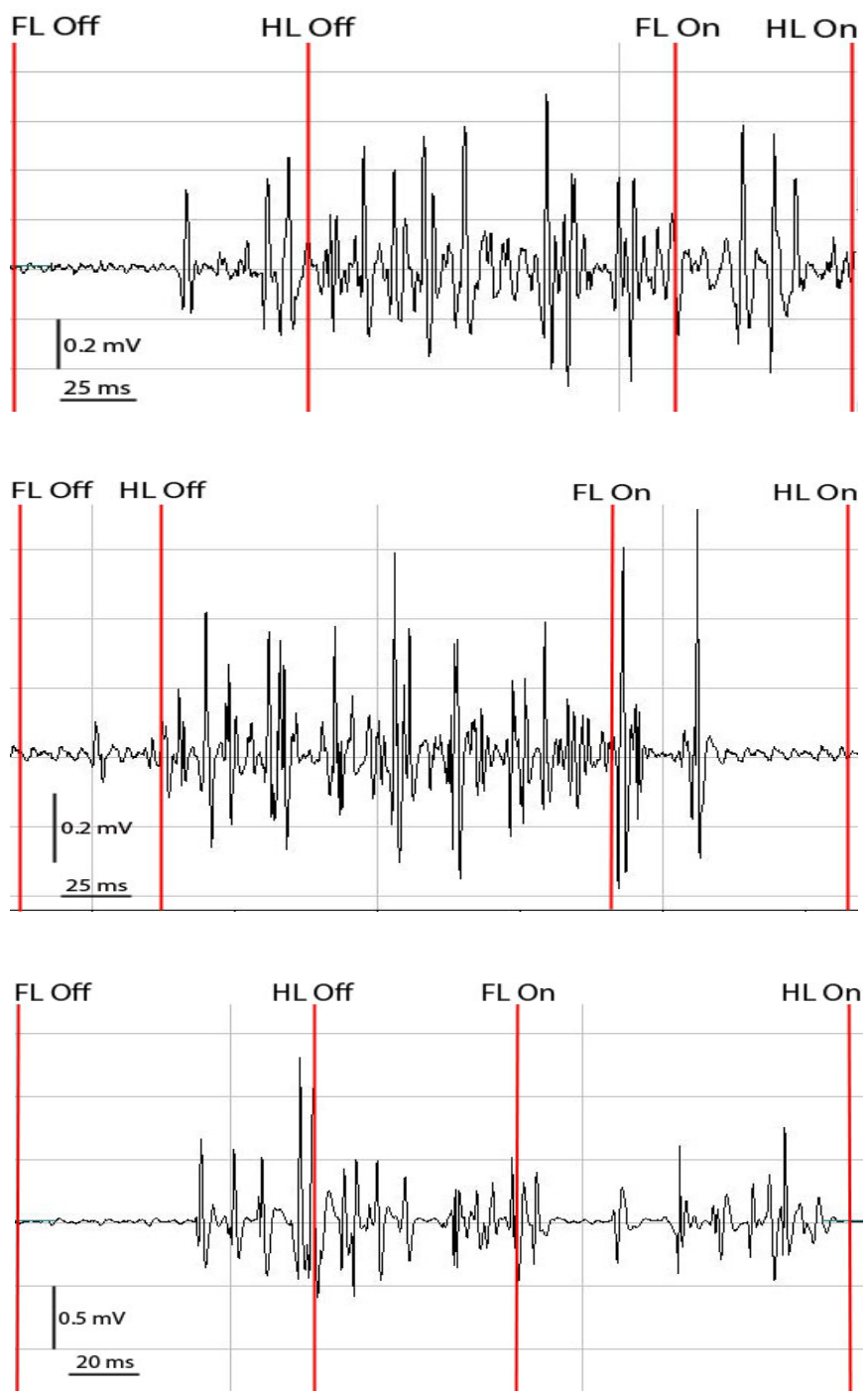

Figure 32. Representative muscle activity patterns from the coracoradialis for a jump of approximately 25 cm in A. grass frog B. bullfrog C. Cane toad showing how the timing of the onset of coracoradialis activity is later in the grass frog and bullfrog than in the cane toad.

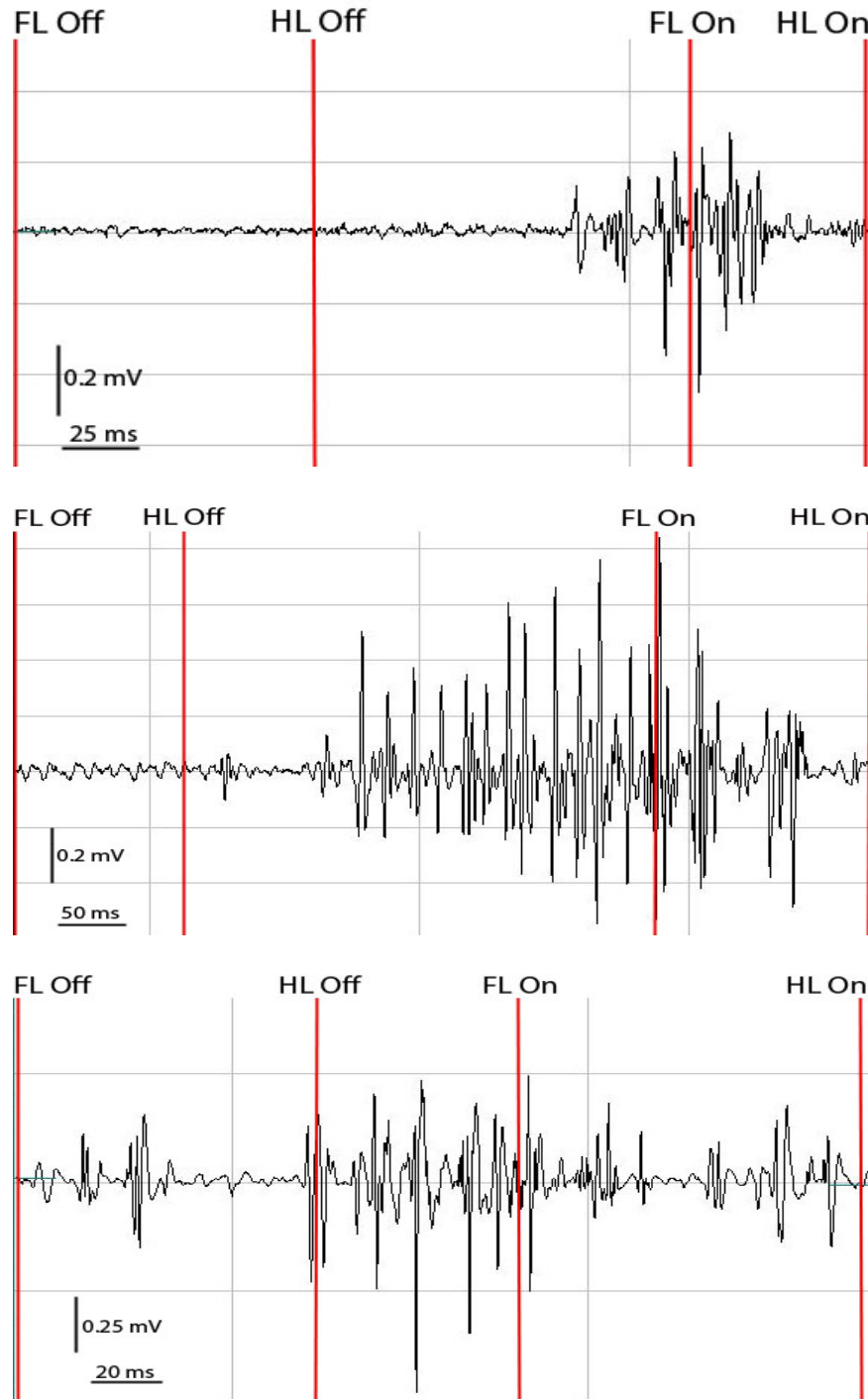

Figure 33. Representative muscle activity patterns from the anconeus for a jump of approximately 25 cm in A. grass frog B. bullfrog C. Cane toad showing how the timing of the onset of anconeus activity is later in the grass frog and bullfrog than in the cane toad.

Muscle Tuning

Many animals, including humans and other mammals, are known to alter the timing and intensity of muscle recruitment before landing depending on jump height or distance. For example, leg muscles of humans and forelimb muscles of cats are recruited later after the onset of a jump and more intensely during higher jumps (McKinley et al, 1983; Santello and McDonagh, 1998). This timing difference enables the animal to consistently turn on the muscle at a fixed time from impact, helping to stabilize the limb during landing (Santello and McDonough, 1998; McKinley et al., 1983). The timing change also reduces the risk of injury as the forces of impact on landing are greater during higher jumps (Nauwelaerts and Aerts, 2005) and thus more muscle is needed to counteract the ground reaction forces and brace the limb.

In one grass frog and one bullfrog, the onset latency of coracoradialis activity increased with increasing hop distance. On average, activation timing occurred 150 ms prior to impact in grass frogs and 200 ms prior to impact in bullfrogs. The pre-landing intensity of the coracoradialis increased with increasing hop distance in two of the grass frogs and two of the bullfrogs. These patterns indicate that some grass frogs and bullfrogs are at least capable of tuning the activation timing and pre-landing intensity of the coracoradialis to the distance of the jump, just as has been reported for cane toads (Gillis et al., 2010; Akella and Gillis, 2011). These trends were not present in a number of the animals,

perhaps because of their much smaller hop distance ranges. If these frogs were not capable of tuning the coracoradialis we would not expect to see a pattern like this in any of the animals, or when all of the jumps from all the animals are pooled together.

As in the coracoradialis, in two of the grass frogs and two of the bullfrogs, the onset latency of the anconeus muscle was later in the longer jumps than it was in the shorter jumps. On average, the anconeus is turned on about 110 ms before the forelimbs touch the ground in grass frogs, 125 ms before forelimb touch-down in bullfrogs, and 90 ms before impact in cane toads (Akella and Gillis, 2011). So, while grass frogs and bullfrogs are recruiting their muscles later with respect to take-off than toads, they actually turn them on slightly earlier, on average, relative to landing. This indicates that the frogs are taking more time to prepare for landing than the toads, even though they are turning this muscle on later in the jump with respect to take-off (Akella and Gillis, 2011).

The pre-landing intensity of anconeus recruitment also increased with hop distance in three of the grass frogs and two of the bullfrogs. This increase in intensity is similar to what has been found in cane toads (Gillis et al., 2010; Akella and Gillis, 2011) and implies that grass frogs and bullfrogs are not only capable of tuning the timing and intensity of the coracoradialis but also the anconeus. For both onset latency and pre-landing intensity, animals in which no significant trend was found had the smallest ranges of hop distance.

The ability of some grass frogs and bullfrogs to alter their forelimb muscle recruitment patterns depending on jump distance, just like in more distantly related toads, indicates that this capacity for modulating motor output to muscles important for landing has likely been conserved through anuran evolution, at least among more derived species. It is likely that there is a more primitive common ancestor that initially developed this ability, and it has been maintained in more derived species. This is further evidenced by the fact that the most primitive living anurans known today do not use their forelimbs during landing (Reilly and Jorgensen, 2010) while many of the more derived anurans do. It would be interesting in the future to work with increasingly more primitive species of anurans to see if there is a progression in muscle tuning ability. It might also enable us to determine where in the line of anurans this ability evolved, and how long ago it was. This conservation of neuromuscular pathways is common in studies of quadrupedal locomotor patterns. For example, Ashley-Ross (1995) showed that the recruitment patterns of some ventral limb muscles used during walking are consistent between some salamanders, reptiles, birds and mammals. And Rivera et al., (2011) showed that recruitment patterns of the coracobrachialis, a pectoral muscle, is nearly identical in divergent species of turtle that use their forelimbs for different swimming motions.

LITERATURE CITED

- Akella, T., and G. B. Gillis. "Hopping Isn't always about the Legs: Forelimb Muscle Activity Patterns during Toad Locomotion." *Journal of experimental zoology. Part A, Ecological genetics and physiology* 315.1 (2011): 1-11. Print.
- Alberts, Bruce. *Essential Cell Biology*. New York: Garland Science, 2009. Print.
- Alexander Pyron, R., and John J. Wiens. "A Large-Scale Phylogeny of Amphibia Including Over 2800 Species, and a Revised Classification of Extant Frogs, Salamanders, and Caecilians." *Molecular phylogenetics and evolution* 61.2 (2011): 543-83. Print.
- Allott, Andrew, and David Mindorff. *IB Biology Course Companion*. Oxford, United Kingdom: Oxford University Press, 2007. Print.
- Campbell, Neil, Jane Reece, and Eric Simon. *Essential Biology*. 2nd ed. Pearson, 2004. Print.
- Campbell, Neil, and R. Rendina. *Biology*. 7th ed. California: Pearson Education, 2005. Print.
- Ecker, Alexander. "Muscles of the Anterior Extremity." *The Anatomy of the Frog*. Tran. George Haslam. 4th ed. London England: Oxford Clarendon Press, 1889. 75-94. Print.
- Emerson, Sharon B. "Functional Analysis of Frog Pectoral Girdles. the Epicoracoid Cartilages." *Journal of zoology* 201 (1983): 293,294-308. Print.
- Gillis, G. B., T. Akella, and R. Gunaratne. "Do Toads have a Jump on how Far they Hop? Pre-Landing Activity Timing and Intensity in Forelimb Muscles of Hopping Bufo Marinus." *Biology letters* 6.4 (2010): 486-9. Print.
- Gillis, G. B., and A. A. Biewener. "Hindlimb Extensor Muscle Function during Jumping and Swimming in the Toad (Bufo Marinus)." *The Journal of experimental biology* 203.Pt 23 (2000): 3547-63. Print.
- Hoegg, S., et al. "Phylogeny and Comparative Substitution Rates of Frogs Inferred from Sequences of Three Nuclear Genes." *Molecular biology and evolution* 21.7 (2004): 1188-200. Print.

- Holmes, Samuel. "The Amphibia in General and Frogs in Particular." *The Biology of the Frog*. 4th ed. New York: The Macmillan Company, 1927. 1-28. Print.
- Kargo, W. J., and L. C. Rome. "Functional Morphology of Proximal Hindlimb Muscles in the Frog *Rana Pipiens*." *The Journal of experimental biology* 205.Pt 14 (2002): 1987-2004. Print.
- Loeb, Gerald, and Carl Gans. "Design and Construction of Electrodes." *Electromyography for Experimentalists*. Chicago, IL: The University of Chicago Press, 1986. 109-22. Print.
- McKinley, P. A., J. L. Smith, and R. J. Gregor. "Responses of Elbow Extensors to Landing Forces during Jump Downs in Cats." *Experimental brain research. Experimentelle Hirnforschung. Experimentation cerebrale* 49.2 (1983): 218-28. Print.
- Nauwelaerts, S., and P. Aerts. "Take-Off and Landing Forces in Jumping Frogs." *The Journal of experimental biology* 209.Pt 1 (2006): 66-77. Print.
- Noble, Kingsley. *The Biology of the Amphibia*. 1st ed. New York, New York: McGraw-Hill Company, 1931. Print.
- Peters, Susan E., Lynn T. Kamel, and David P. Bashor. "Hopping and Swimming in the Leopard Frog, *Rana Pipiens*: I. Step Cycles and Kinematics." *Journal of Morphology* 230.1 (1996): 1-16. Print.
- Plowman, Sharon, and Denise Smith. *Exercise Physiology for Health, Fitness and Performance*. 2nd ed. Philadelphia Pennsylvania: Lippincott, 2008. Print.
- Reilly, Stephen M., and Michael E. Jorgensen. "The Evolution of Jumping in Frogs: Morphological Evidence for the Basal Anuran Locomotor Condition and the Radiation of Locomotor Systems in Crown Group Anurans." *Journal of Morphology* 272.2 (2011): 149-68. Print.
- Rivera, A. R., J. Wyneken, and R. W. Blob. "Forelimb Kinematics and Motor Patterns of Swimming Loggerhead Sea Turtles (*Caretta Caretta*): Are Motor Patterns Conserved in the Evolution of New Locomotor Strategies?" *The Journal of experimental biology* 214.Pt 19 (2011): 3314-23. Print.
- Roberts, T. J., and R. L. Marsh. "Probing the Limits to Muscle-Powered Accelerations: Lessons from Jumping Bullfrogs." *The Journal of experimental biology* 206.Pt 15 (2003): 2567-80. Print.

Santello, M., and M. J. McDonagh. "The Control of Timing and Amplitude of EMG Activity in Landing Movements in Humans." *Experimental physiology* 83.6 (1998): 857-74. Print.

Sherwood, Lauralee. *Fundamentals of Human Physiology*. 4th ed. Belmont California: Cengage Learning, 2010. Print.

Thompson, Arthur. *Outlines in Zoology*. New York, New York: Appleton and Co, 1916. Print.

"Toads and Frogs." *United States Geological Survey*. jWeb. US Department of the Interior.
<http://fl.biology.usgs.gov/Region_5_Report/html/toads_and_frogs.html>.

Wells, Kentwood D. "Anuran Body Plan and Modes of Locomotion." *The Ecology and Behavior of Amphibeans*. Chicago, Il: The University of Chicago Press, 2007. 46-47. Print.